

SRT

(20),

20

20

0 35

75

IP67,

20 35

-
-
-
-
-
-
-
-
-
-
-
-

	10 , 125/250 . 1/2 125 . SPDTx2
	3,4-5,4 N.m (0.35-0.55 kgf.m)
	-20-60
	IP67
	ADC
	2,9

DIMENSION

SRT

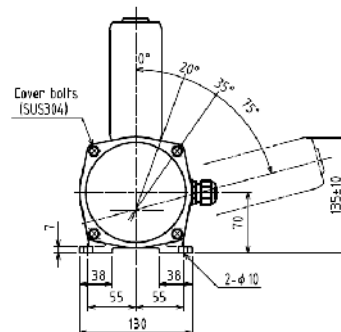
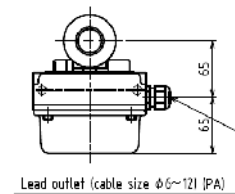
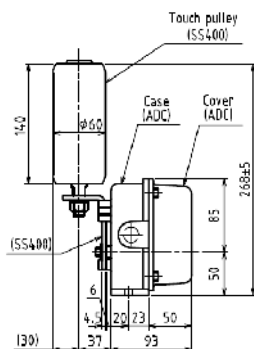

SRS

SRS

-
-
-
-
-
-
-
-
-
-
-
-

/
/

IP67

30

	10 , 125/250	1/2	125	SPDTx2
	49+/-9,8n (5+-1 kgf.m)			
	-20-60			
	IP67			
	ADC			
	2,9			

- Draglines
- Ship Loading / Unloading System
 - Horizontal Feed Systems

DIMENSION

SRS

