

# OPERATION PRINCIPAL

The HYCMWS-ST/SR type microwave sensor is a level switch consisting of a transmitter (HYCMWS-ST) and a receiver (HYCMWS-SR) installed face-to-face.

The transmitter emits a continuous, low power microwave beam towards the receiver and an output relay is released when the beam is obstructed.

The sensor has wide application across all areas of industry where highly reliable, non-contact level detection is required. The sensor is generally used for process control by monitoring presence/absence of product, flow/no flow conditions and point level detection in bins and silos. The sensor may also be used as a proximity switch for detection of vehicles such as dump trucks and rail cars.

## Penetrability of Microwaves

Harsh environments may result in a buildup of contaminants on the sensing head; however, the sensor is easily able to penetrate such buildup thanks to the high penetrability of microwaves.

When microwaves transmitted through air encounter an object, some will be reflected, some absorbed and the rest will pass through the object. The amount of microwaves passing through the object depends on its composition.

Generally speaking, microwaves cannot penetrate metals and are reflected and water absorbs the most microwaves.

Microwaves can easily pass through plastics, glass, ceramic, paper etc.

## Safety of Microwaves & CE Certification

This sensor has been fully tested by a NATA Accredited Laboratory and fulfills all the

legal requirements of the EEC directives including the R&TTE, EMC and LMV Directives. There are no health hazards to personnel operating HYCONTROL sensors: no license, approval or caution sign posting is required.

## Heterodyne vs. Diode Detection

The HYCMWS-ST/SR level switch is the first of its kind to utilize the heterodyne detection method rather than the, now obsolete, diode detection method.

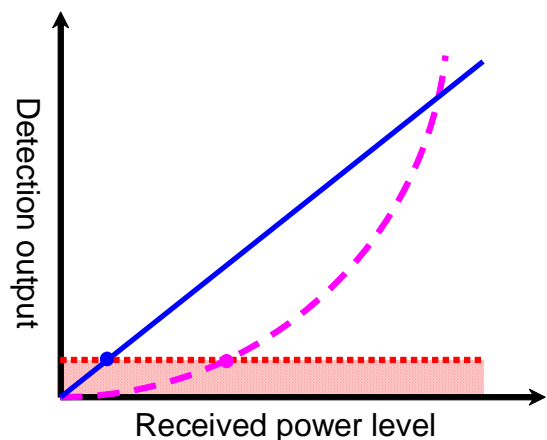

- Heterodyne method
- - - Diode method (commonly used)
- ..... Noise level
- Minimum received power: -70dBm
- Minimum received power: -50dBm

The heterodyne detection method gives detection output that is proportional to the received power level, whereas the diode detection method gives detection output that is proportional to the square of the received power level.

Therefore the heterodyne method allows detection with a minimum received power that is lower than that of the minimum level required by the diode detection method. This increases the operating range/penetrability without any increase in the power of the transmitted microwave radiation.

# FEATURES

## 40m Range with heterodyne detection

Approx. 40m range with a Ø27mm antenna, due to the Heterodyne detection method.

## High penetration

Easily penetrates process buildup on the antenna, and will pass through plastics, firebrick etc..

## Unaffected by adverse environments

The sensor is unaffected by surface contaminants, flames, steam, vapor or airborne particles.

## Simple beam alignment

Easy initial beam alignment at installation, due to the wide beam angle.

## 15 LED indicator bank

A 15 LED indicator array displays the received power level **and** the sensitivity-set-point, allowing for **visual sensitivity adjustment** and maintenance.

## Selectable detection mode

Either broken beam (BLOCK) or unbroken beam (UNBLOCK) detection method may be selected.

## On delay time

On delay time, adjustable 0.1~10secs., prevents instantaneous detection of falling material whist filling.

## Lightweight, compact & simple to install

The transmitter/receiver weighs less than 1kg and is housed in a compact aluminum diecast enclosure. Built-in amplifiers mean no interconnection between transmitter and receiver is necessary.



Transmitter



Receiver

## RECEIVER CONTROLS

Beam unobstructed

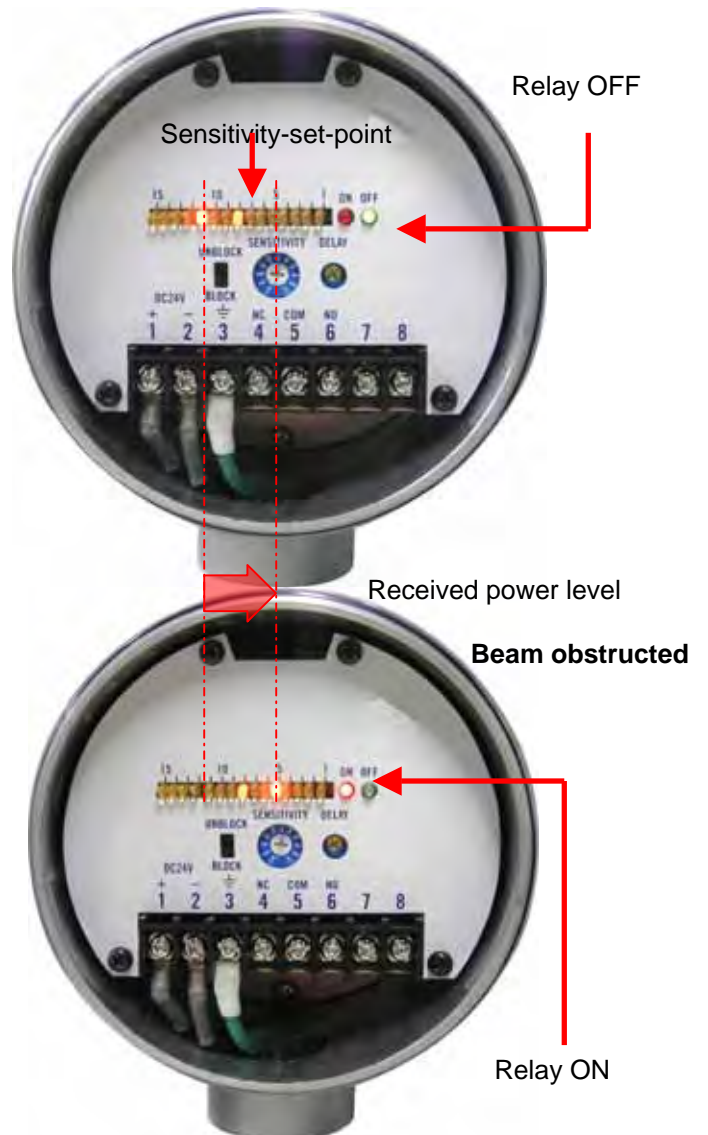

# SPECIFICATIONS

---

## Type

Transmitter : HYCMWS-ST-2-24V  
Receiver : HYCMWS-SR-2-24V

## Power supply

Transmitter : 24VDC  $\pm$ 10%  
Receiver : 24VDC  $\pm$ 10%

## Power consumption

Transmitter : 1W, 42mA  
Receiver : 2W, 83mA

## Operating distance

Up to 40 meters  
*Note: Operating distance may vary on different applications due to installation limitations.*

## Frequency & transmission power

Approx. 24GHz, less than 100mW E.I.R.P.

## Received power level

Indicated by 1 of 15 LED indicators  
*Note: Indicator is fully illuminated*

## Sensitivity-set-point

Indicated by 1 of 15 LED indicators  
*Note: Indicator is half illuminated*

## Radiation angle

Approx.  $\pm$ 20° (angle in half of receiving value)

## Output contact

1 (SPDT) relay 30VDC, 2A contact

## Condition of output function

Output occurs on change of state, but only after any delay period has past. Output relay is unexcited during output state.

## Response time

10msec.

## On delay function

0.1 ~ 10sec. adjustable

## Delay time from power on to function

Transmitter : Approx. 50msec.  
Receiver : Approx. 5sec

## -Operating ambient temperature

-10°C ~ +55°C

*Note: Optional hardware is available for high temperature applications. Contact Hycontrol.*

## Non-function ambient temperature

-20°C to +70°C

## Continuous maximum pressure

0.5Mpa (75psi)

*Note: Optional hardware is available for high pressure applications.*

## Enclosure rating

IP65 Protection

## Enclosure construction

Diecast aluminum, Pointed

## Weight

Transmitter : 1kg  
Receiver : 1kg

## CE Certification Standards

R&TTE to EN300440-1/2  
EMC to EN301489-1/3 & EN61000-6-2  
LVD to EN60950-1

# APPLICATIONS

## Standard Applications

### Blocked Chute Detection

*Note: Install the sensors behind the material flow to avoid false detection.*

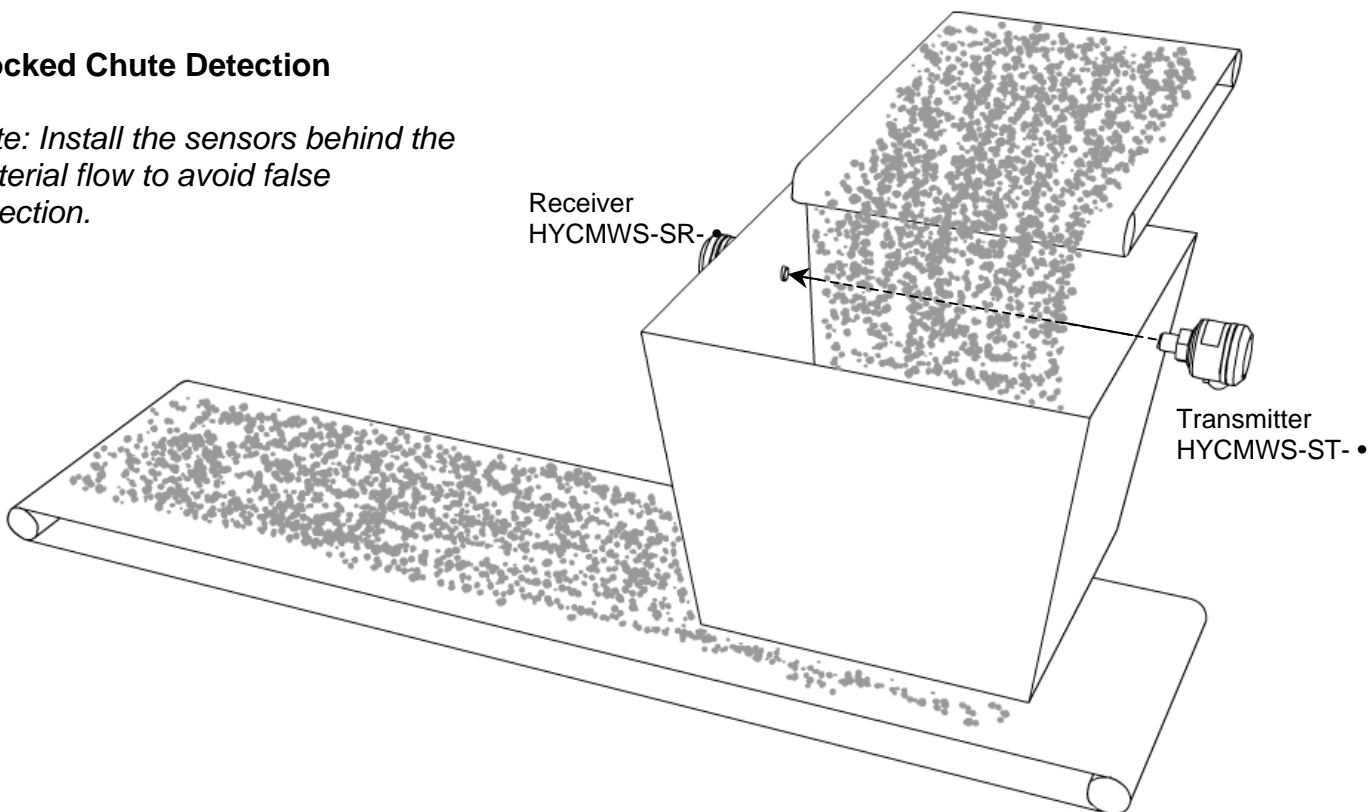

### Hi/low level of liquids in tanks, and other storage vessels.

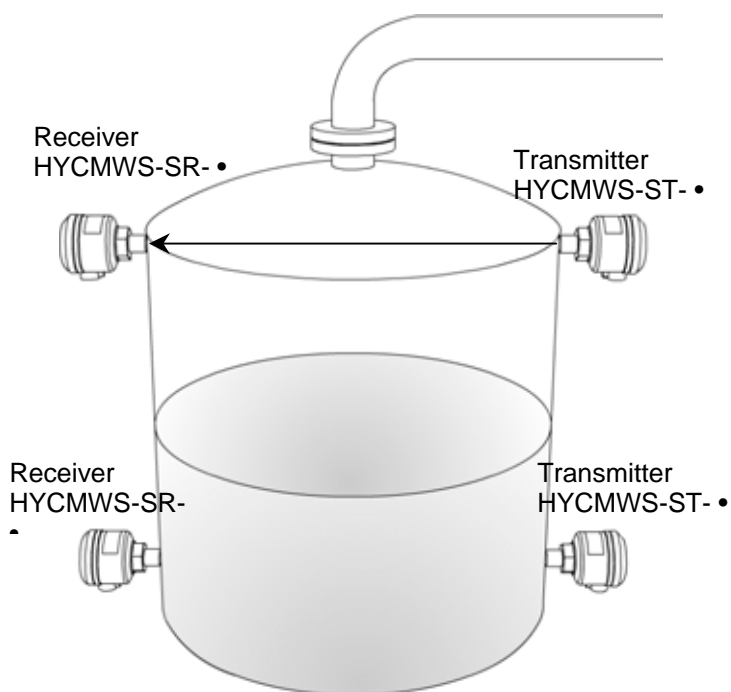
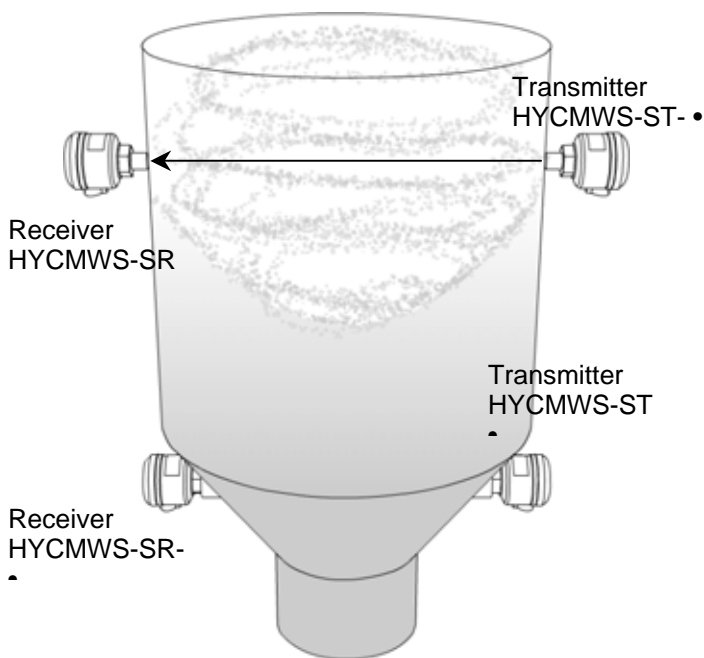

## Vehicle detection & positioning

Trucks and heavy vehicles; reliable detection through heavy dust is assured.

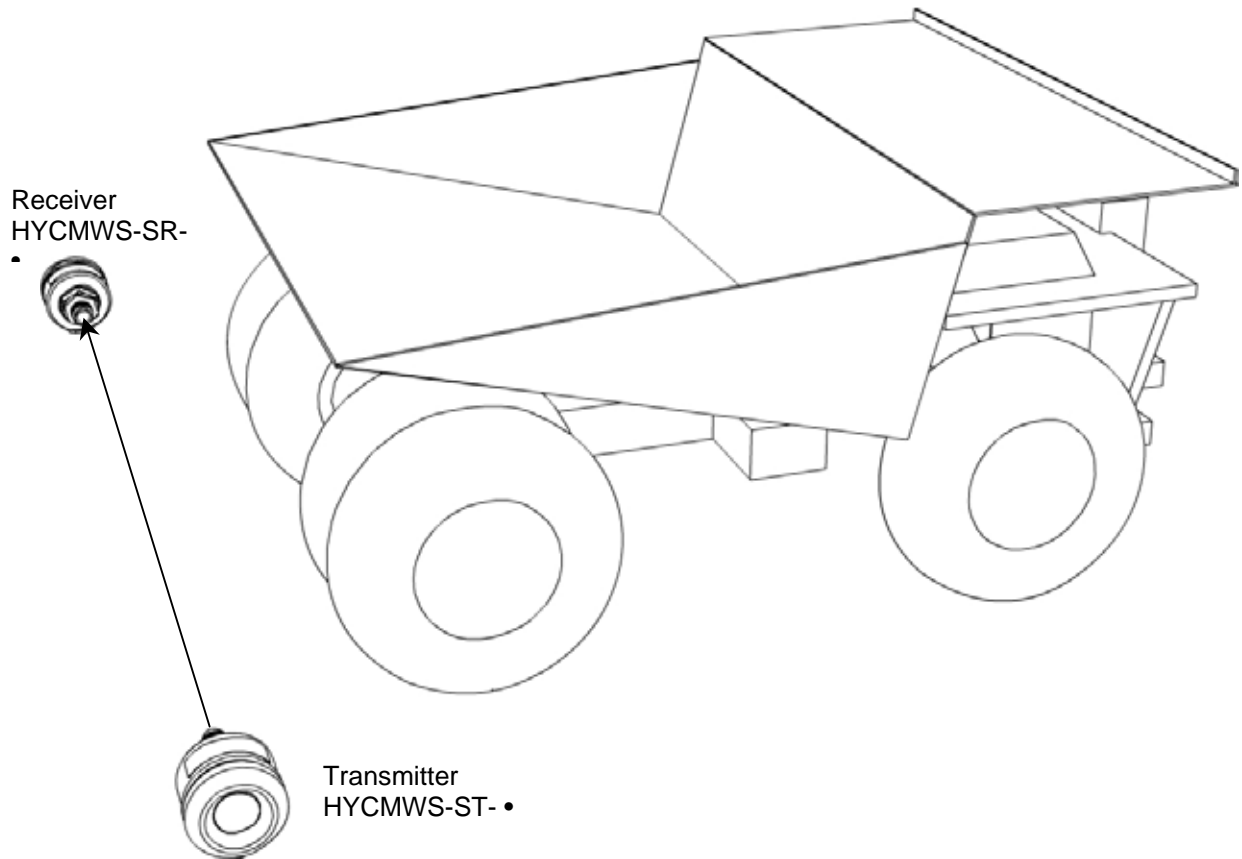

Trains and rail cars; reliable detection under all weather conditions is assured.

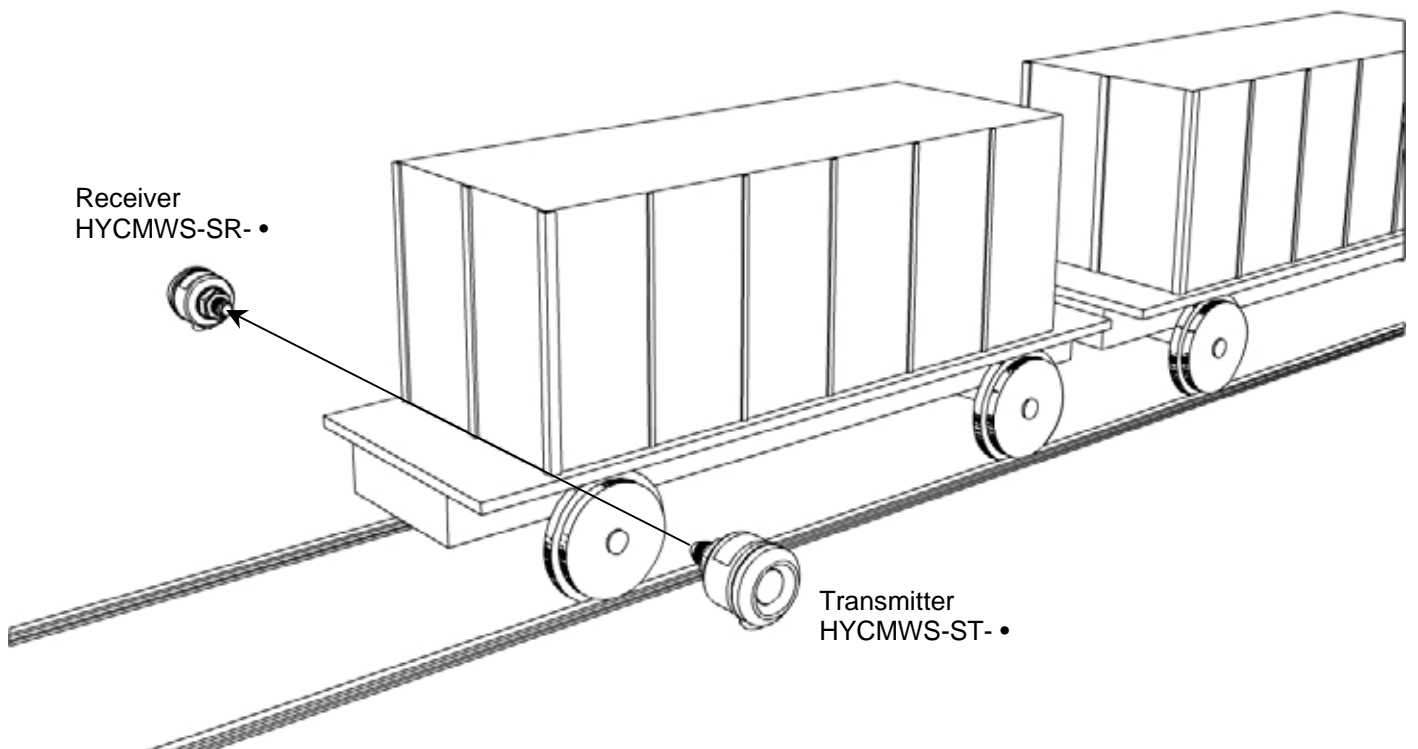

# High Pressure Applications

## NP Type

Polypropylene plug with flange mounting.

*Note: See HARDWARE OPTIONS for more details.*

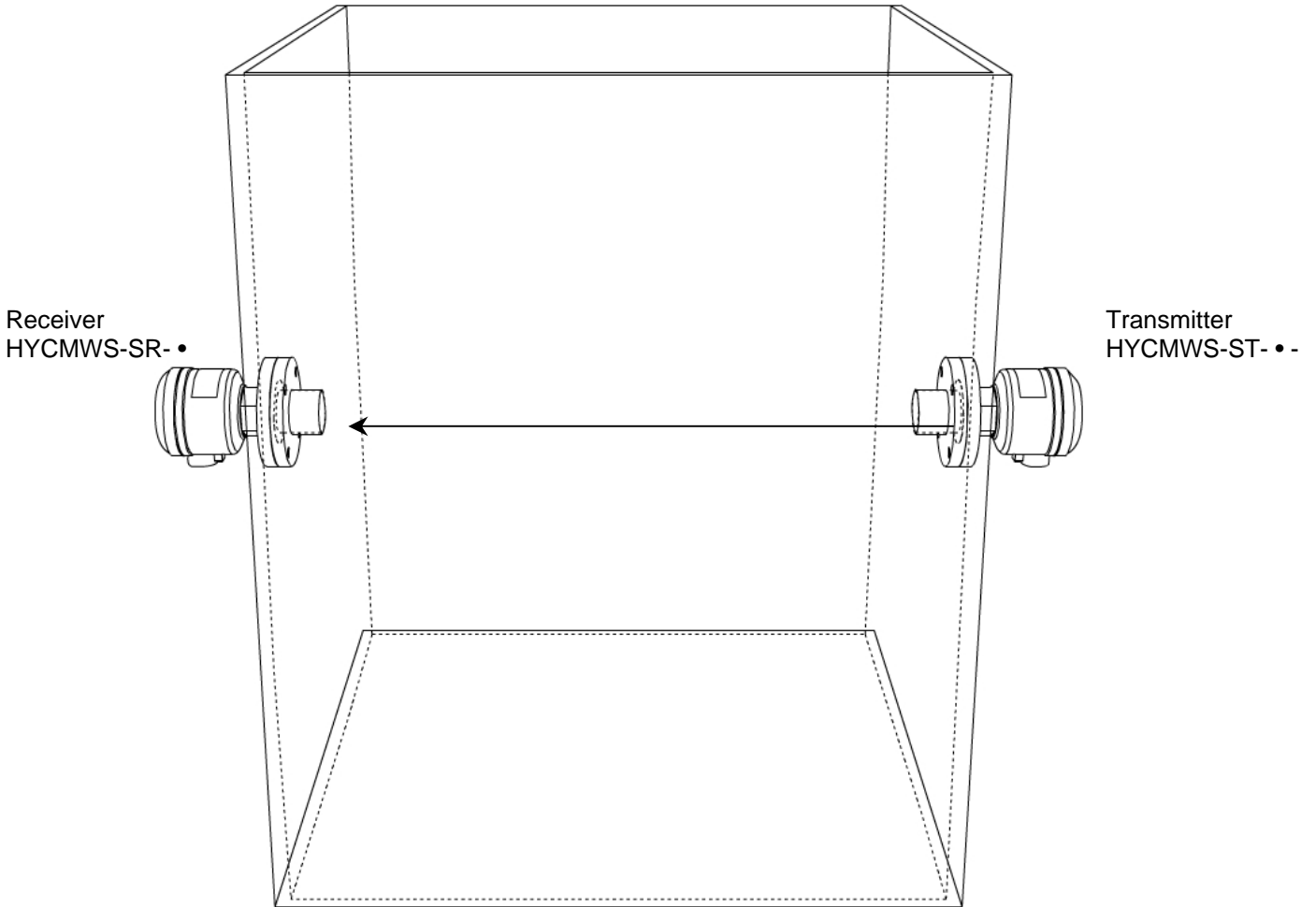

## Mounting detail

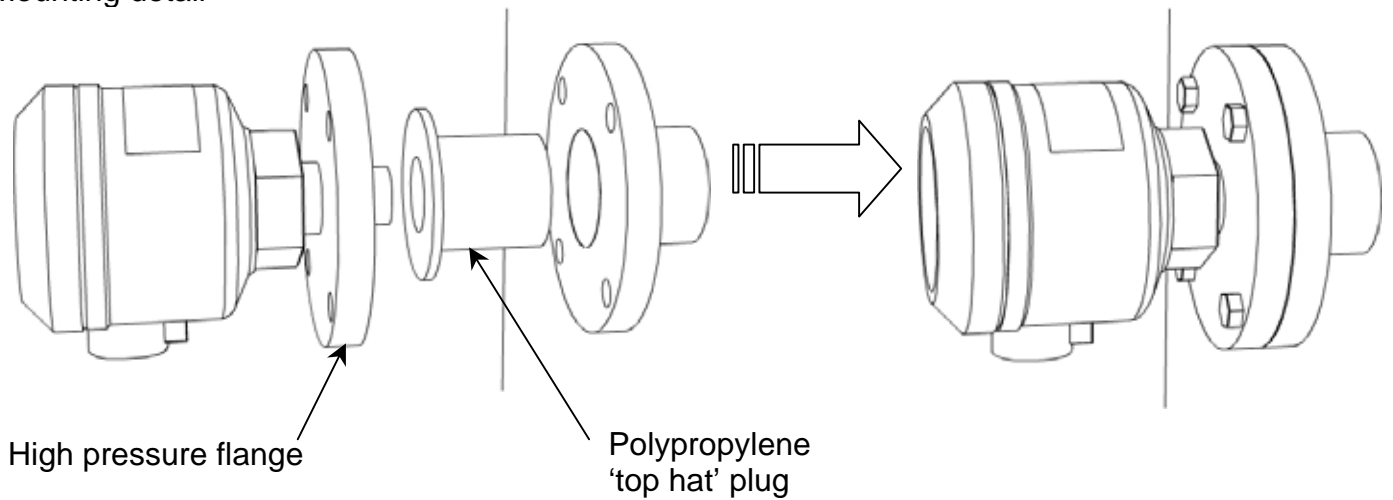

# High Vibration & Hazardous Applications

## Isolated, Non-invasive Mounting

Sensors may be protected from high temperatures, hazardous materials, vibration and shock by providing detecting windows through which the microwaves can pass.

Detecting windows should be made of ceramic, glass, Teflon or polypropylene materials having no water content, through which there is minimal loss of microwave energy.

The detecting windows should be at least 60mm in diameter as microwaves pass more easily through larger apertures. The distance between the window and the antenna should be less than 200mm.

The sensors should be fixed to an isolated support structure to protect against high vibration.

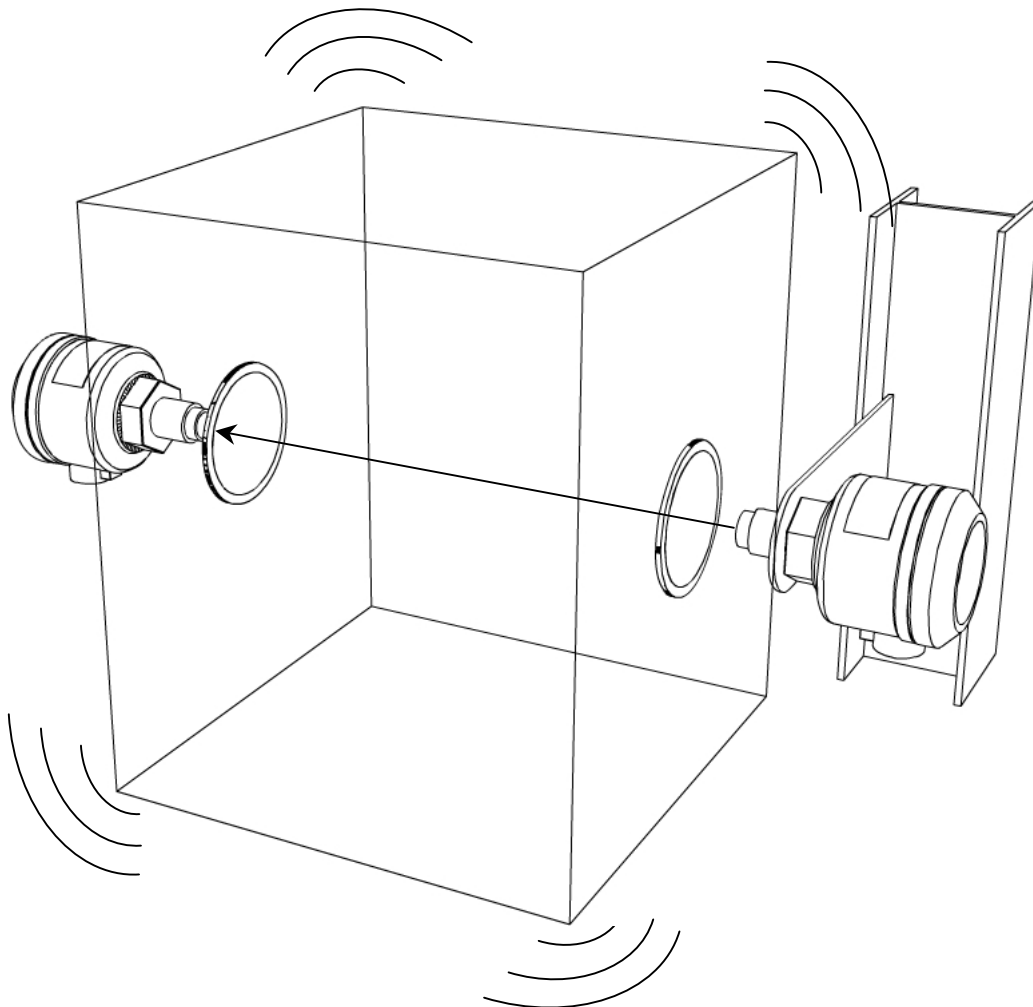

# HARDWARE OPTIONS

---

## Standard: Diecast Aluminum Antenna Head with Teflon Antenna cover

The standard enclosure is suitable for most applications that do not exceed the general specifications (temperature, pressure, vibration etc).

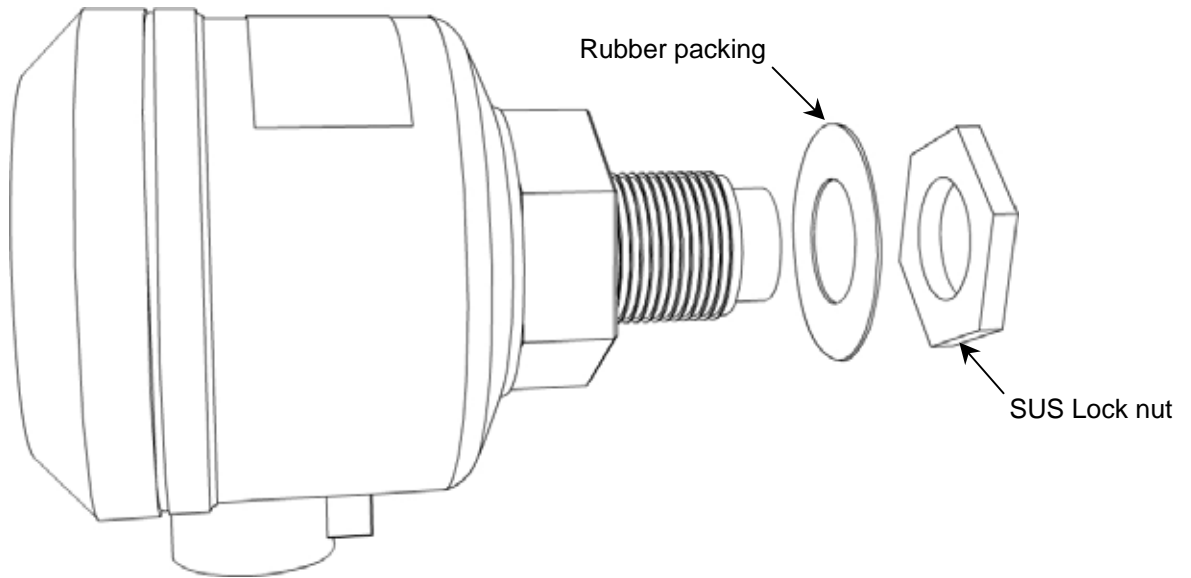

## Standard (as above) with Optional Flange Mounting

Threaded flanges are available in most standards (JIS, DIN, ANSI etc).

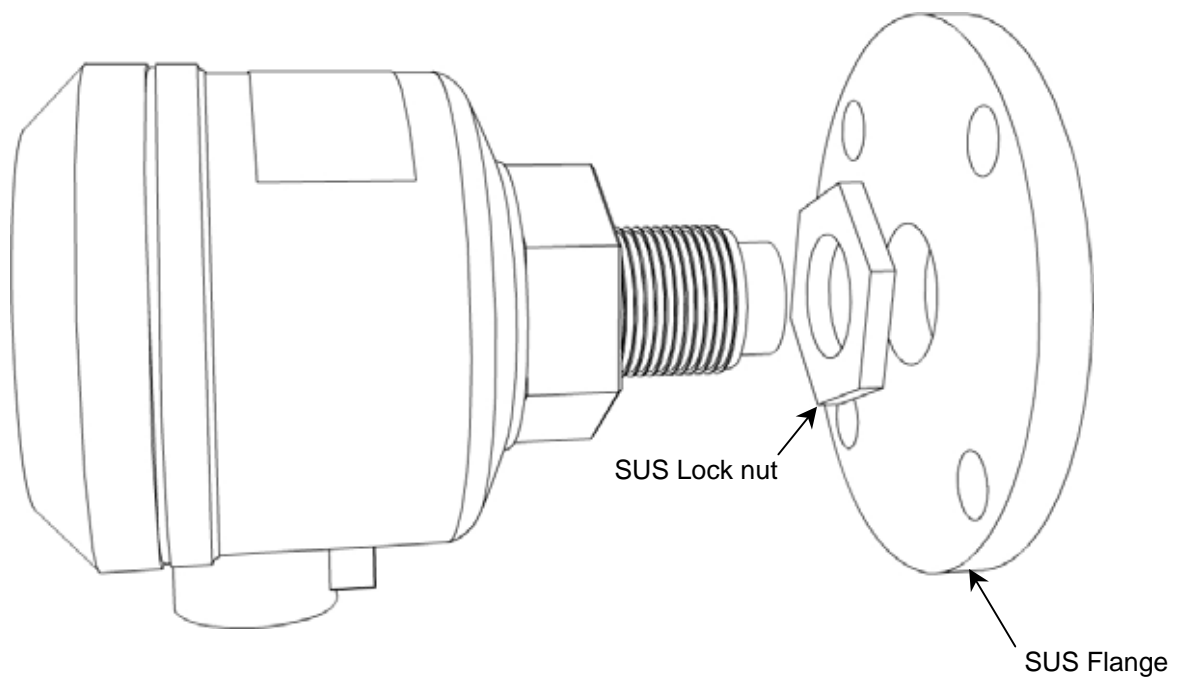

## Optional NP Type: Polypropylene Head and Flange

The NP type is useful for applications where the process material is conductive and tends to buildup, impairing the microwaves; the polypropylene plug should be placed into the standoff portion preventing material from entering the standoff.

The NP type, when combined with a high pressure flange/seal, is also suitable for high pressure applications. Threaded flanges are available in most standards (JIS, DIN, ANSI etc).

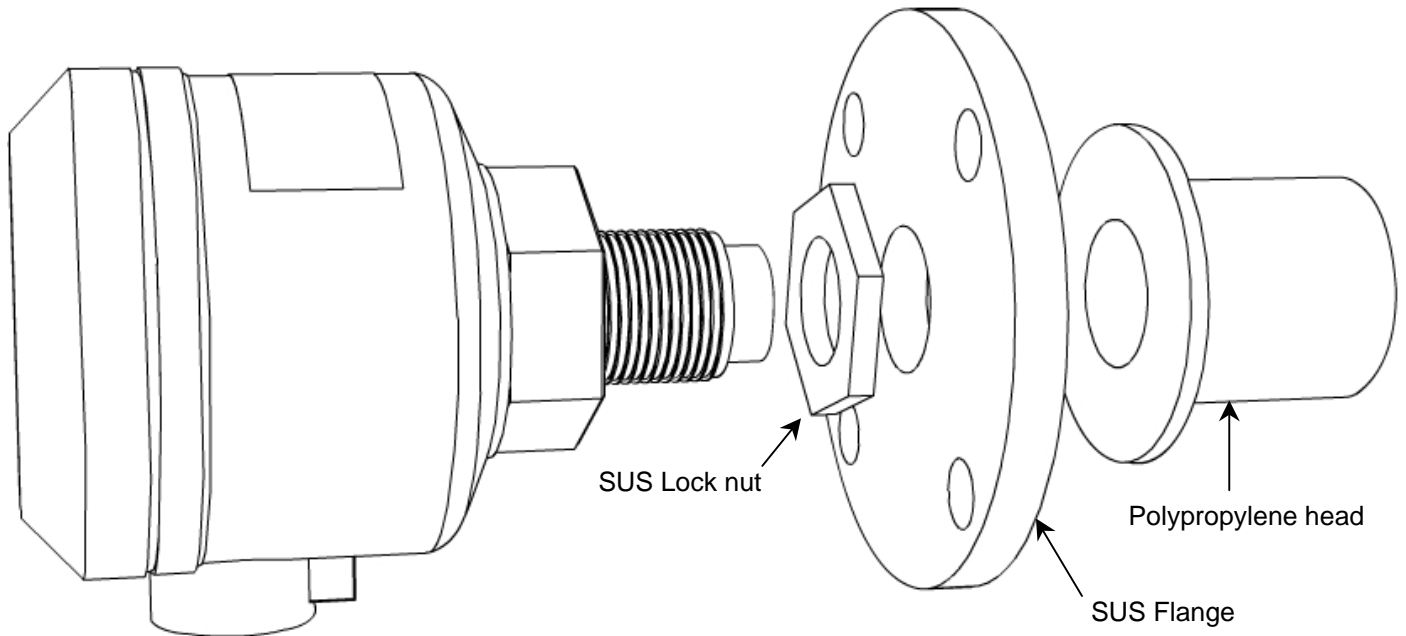

# DIMENSIONS & PART NUMBERS

Note: Hardware dimensions are same for both the transmitter and receiver.

## Standard

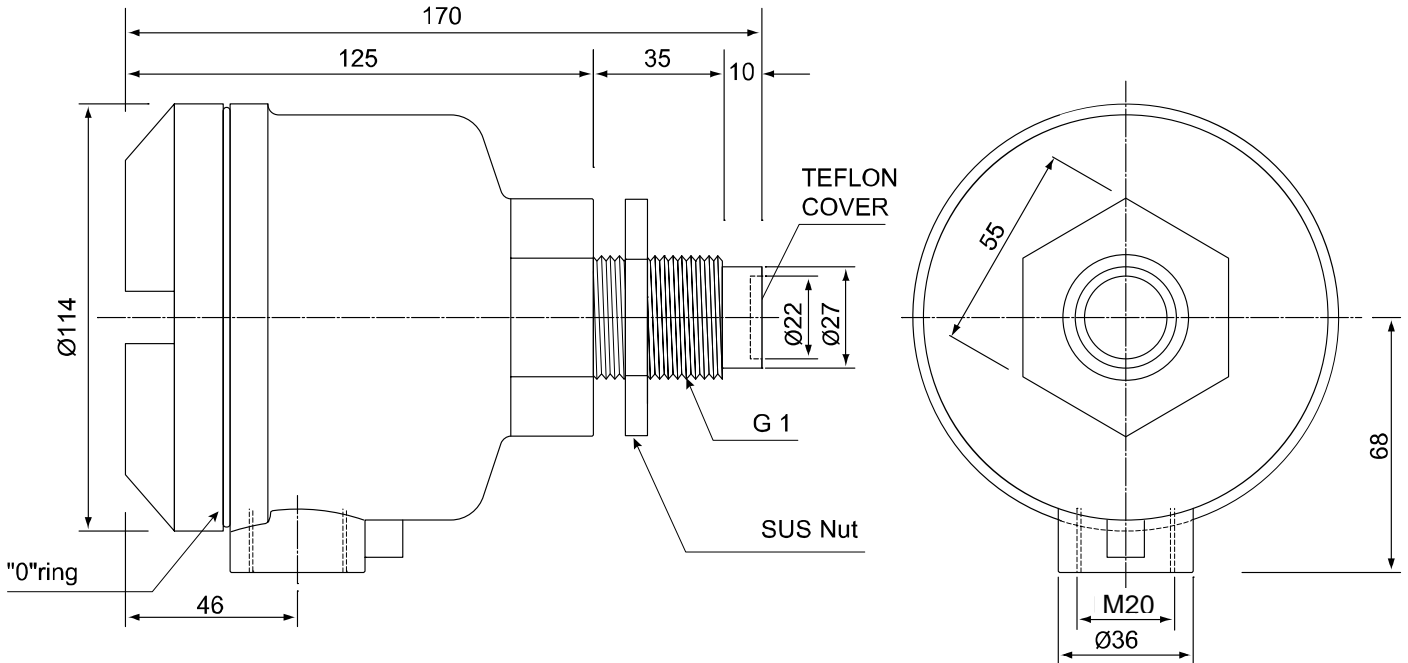

## Flange Mounting

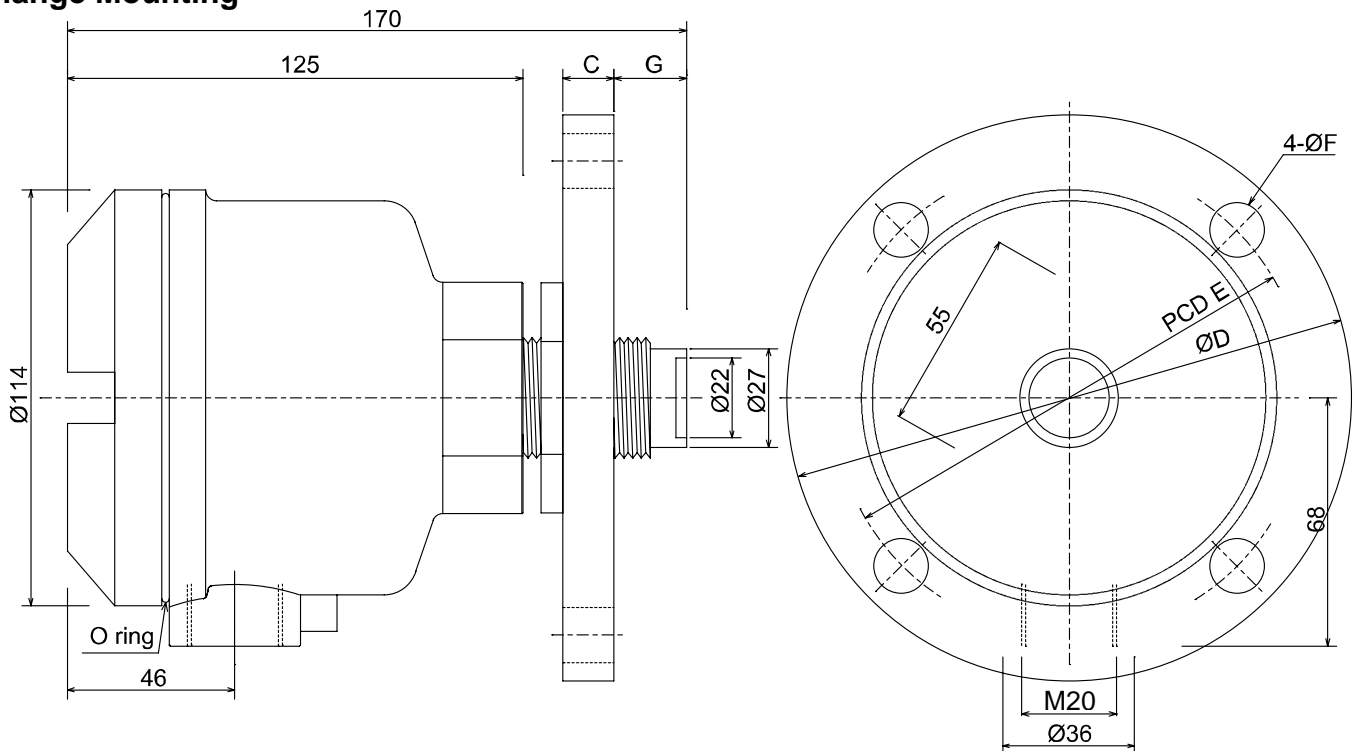

NOTE: Other flange sizes are available upon request.

## NP Type

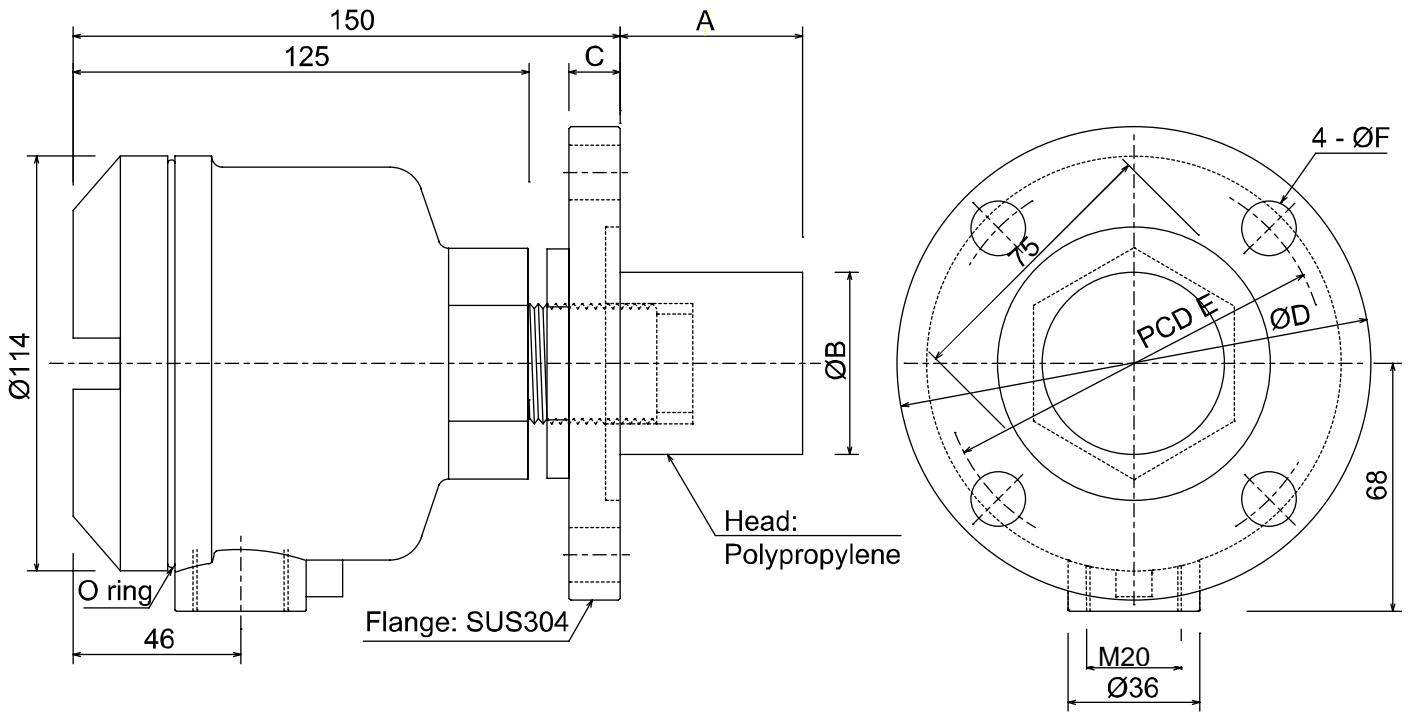

## OPTIONS

Head Length (A)    050: 50mm  
                               075: 75mm  
                               100: 100mm

Flange	B	C	D	E	F
ND 50 NP6	50	16	140	110	14
ND 65 NP6	65	16	160	130	14
ND50 NP16	50	20	165	125	18
ND 65 NP16	65	20	185	145	18

*NOTE: Other flanges and polypropylene head lengths are available upon request.*

# INSTALLATION & MOUNTING

## General Guidelines

### Mounting angle

The transmitter emits linear polarized microwaves; as such it is necessary to align the transmitter and its corresponding receiver in the same plane. The cable entry of both the transmitter and receiver should be facing in the same direction, or be 180° opposite each other.

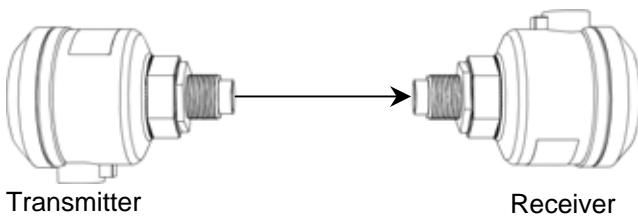
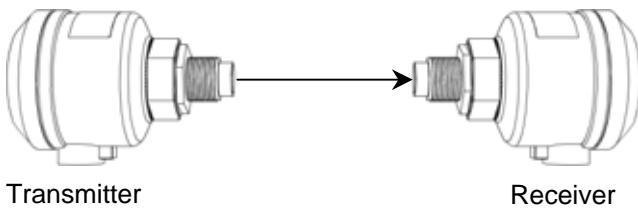

If the units are installed with the cable entries at 90° to each other they will not function.

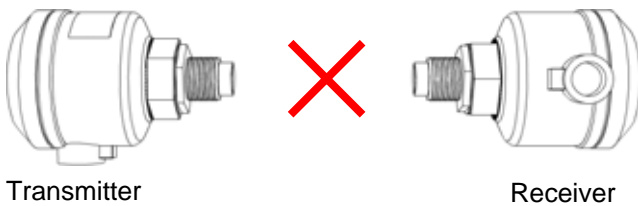

### Elevation angle

The sensors should be mounted with the antennas facing each other on the same horizontal axis.

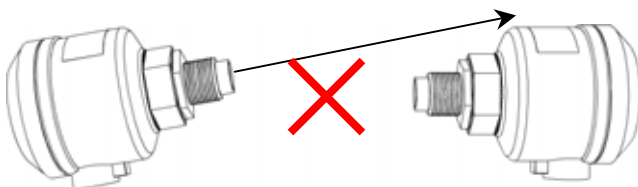

Note that the sensors do not have to be perfectly aligned, thanks to the wide beam angle, however suitable care should be taken.

### Set-to-set interference

If two transmitter receiver sets are installed in close proximity to each other, one set should be mounted at 90° to the other to eliminate set-to-set interference.

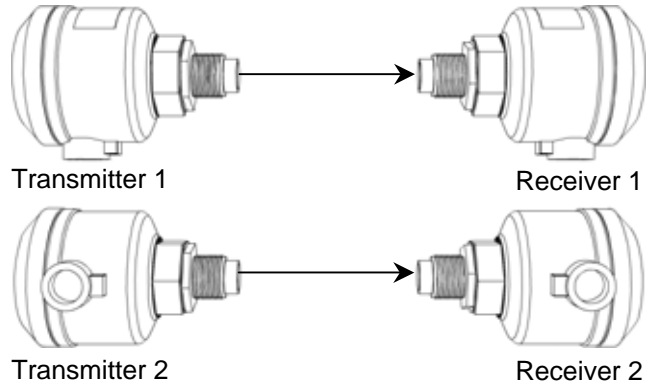

### Mounting flush

It is desirable to mount the units flush so as to minimize material buildup on the antenna. This is especially important if the process material contains moisture. Microwaves are able to penetrate most surface containments; however it is recommended that you optimize the installation to gain maximum reliability.

### Penetrability of walls

Microwaves are able to penetrate walls made from non-conductive materials such as refractory/firebrick, ceramic, plastic, glass etc. Microwaves can not penetrate metallic or conductive wall linings: a hole must be made and a suitable process connection welded to the vessel.

### Received Power Levels LED Margins

In order to reliably detect, the Received Power Level indicator needs to drop at least 3 LEDs when the beam is blocked. In other words, even a Received Power Level of 4 is acceptable, so long as it drops to 1 when the beam is blocked. If a margin of 3 LEDs can not be obtained, contact HYCONTROL or its representative.

# Mounting

## Standard Mounting

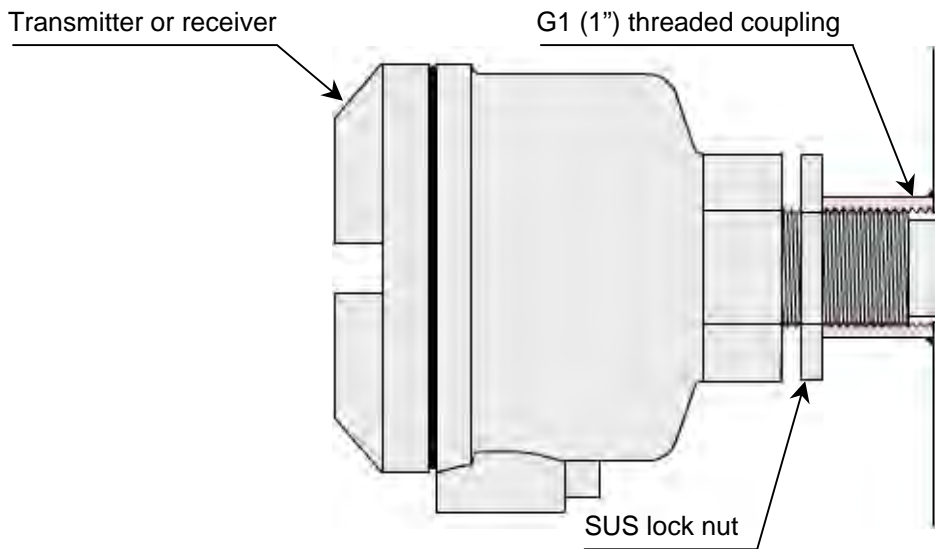

The sensor is threaded into an internal half connector welded to the wall. The sensor should be mounted flush with the inside of the vessel and the SUS lock nut used to fix the sensor in position.

Apply liquid sealant into screw hole and/or any gaps.

## Optional Flange Type Mounting

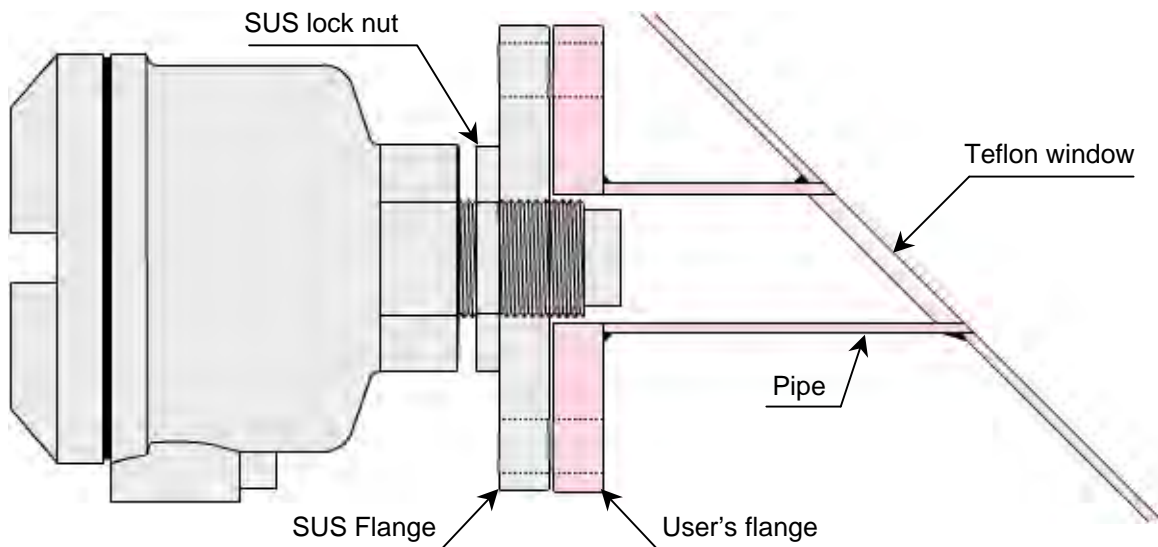

Flanges are optionally available in most standard sizes. The sensor's flange is bolted to the process connection flange supplied by the user.

Installation on sloped walls may be accomplished with a pipe and Teflon window as shown above.

*Note: The length and diameter of the pipe are critical to ensure optimal performance; **consult Hycontrol before deciding on these dimensions**, we will advise you on the most appropriate dimensions for your application.*

## Optional NP Type Mounting

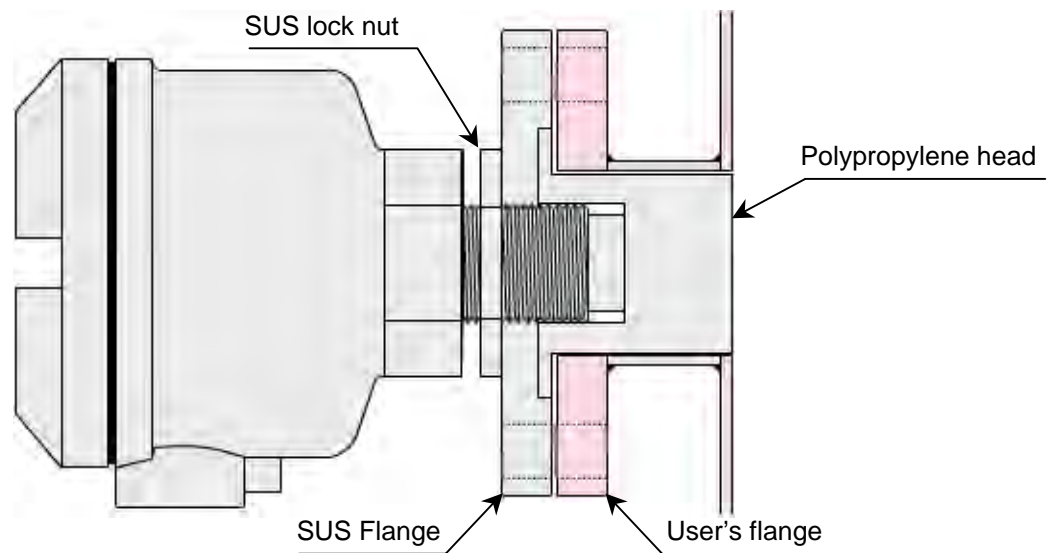

The polypropylene head is placed in the stand-off portion of the pipe and mounted flush with the inside of the vessel.









The polypropylene head is not fixed to the sensor; rather it is sandwiched between the two flanges.

Use suitable gaskets for high pressure applications.

# WIRING

---

## Warning

Do not disconnect the wires connected to ground, either inside or outside the sensor. If they are disconnected it may cause electrocution or damage the circuits.	
Do not touch live terminals of the sensor as voltages may be present.	
Do not disassemble any part of the sensor's electronics.	
Turn off the power before connecting to any terminals. If this is not done electrocution or damaged circuits may result.	
To prevent electrocution, ensure that the ground terminal of the sensor is connected to ground before turning on the power.	
If there are problems with grounded wires, or if other protective functions are absent, do not turn on the power.	
Before turning on the power, confirm that the rated voltage of the controller is compatible with the voltage of the power supply.	
Ensure that the ground wire is connected to earth before connecting any other wires to the controller.	

## Terminal Connection

Transmitter HYCMWS-ST-2-24C

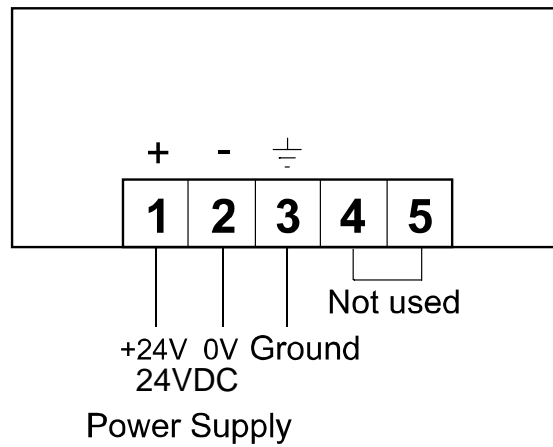

Receiver HYCMWS-SR-2-24C

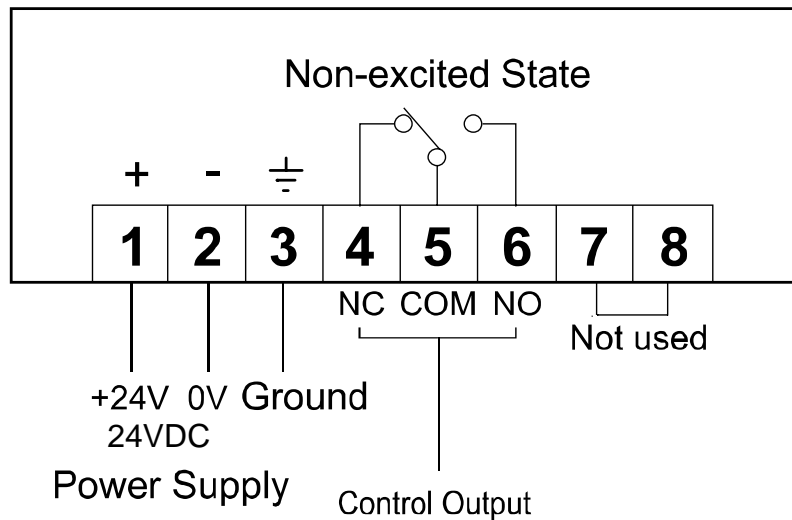

## Selection of Detection Mode and Relay Configuration

Detection Mode		Beam broken BLOCK		Beam unbroken UNBLOCK	
Terminal Number		4 & 5	5 & 6	4 & 5	5 & 6
Non powered state		Closed	Open	Closed	Open
Powered state	Non-detecting state	Open	Closed	Open	Closed
	Detecting state	Closed	Open	Closed	Open

# FUNCTION OF SWITCHES, INDICATORS AND RHEOSTATS

## Transmitter HYCMWS-ST-2-24C

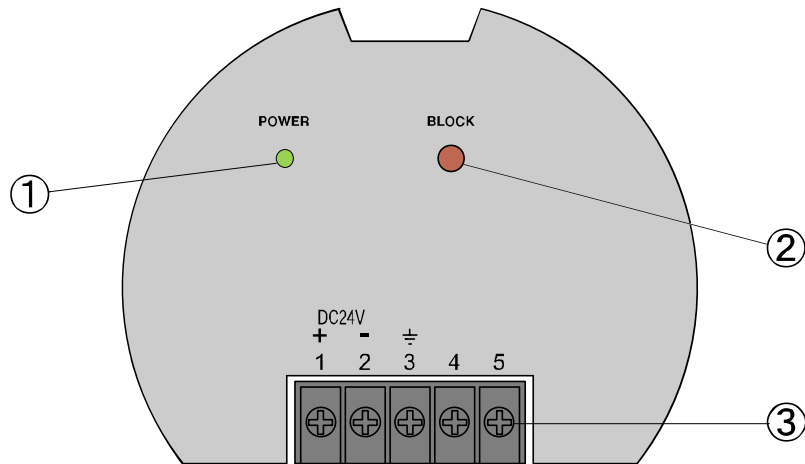

	Part name	Description
①	Power indicator	Green when power is on
②	Block button	Blocks transmission
③	Terminals	

## Receiver HYCMWS-SR-2-24C

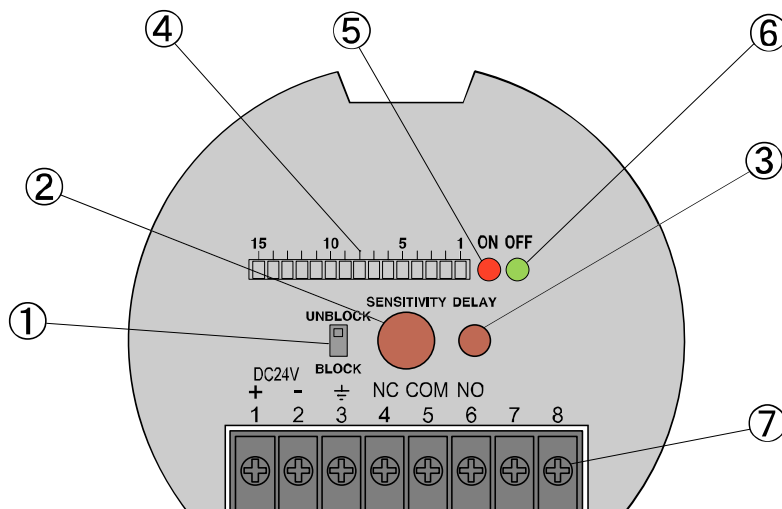

	Part name	Description
①	Mode selection switch	BLOCK: Outputs on broken beam UNBLOCK: Outputs on unbroken beam
②	Sensitivity rheostat	For sensitivity adjustment
③	Delay time rheostat	0.1 ~ 10sec. delay period after state changes
④	15LED indicator array	Received power level: indicated by one of 15 LEDs Sensitivity-set-point: indicated by one of 15 LEDs
⑤	Output indicator	ON (red): Illuminates on output
⑥	Output indicator	OFF (green): Illuminates on no output
⑦	Terminals	

# SENSITIVITY ADJUSTMENT

## Before adjusting the sensitivity:

- Ensure that there is a clear line of sight between the transmitter and receiver,

## Transmitter HYCMWS-ST-2-24C

- Apply power to the unit. The green POWER indicator will illuminate.

## Receiver HYCMWS-SR-2-24C

- Apply power to the unit. Either the red ON or the green OFF indicator will illuminate.
- Set the mode selection switch to BLOCK. Turn sensitivity rheostat fully counter clockwise (minimum).
- Turn the delay time rheostat fully counter clockwise (minimum).
- The red output indicator ON will illuminate.
- The sensitivity is adjusted visually using the 15LED indicator array. The received power level and sensitivity-set-point are indicated on the receiver by a bank of 15 LEDs. Turn the sensitivity rheostat clockwise until the sensitivity-set-point is located halfway between the received power level in the BEAM UNOBSTRUCTED and the BEAM OBSTRUCTED states.

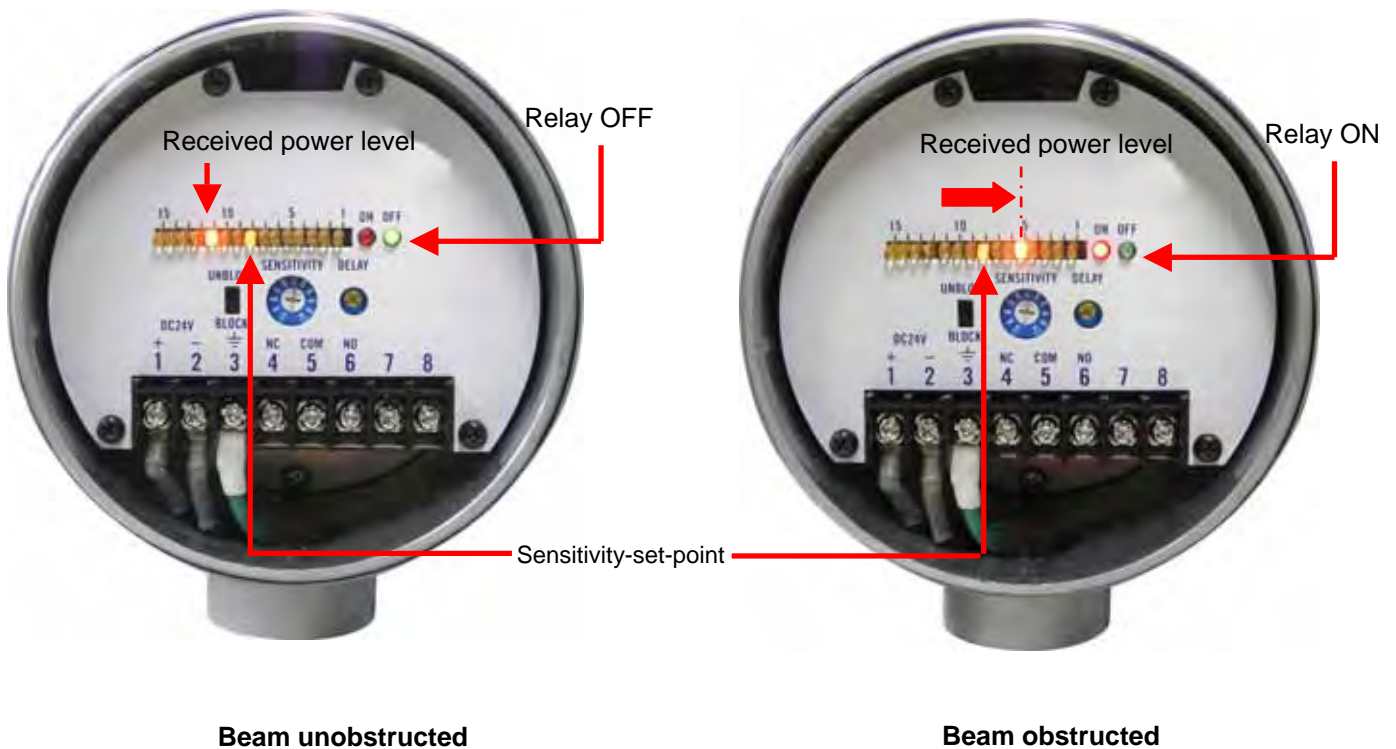

- In order to reliably detect, the Received Power Level indicator needs to drop at least 3 LEDs when the beam is blocked. In other words, even a Received Power Level of 4 is acceptable, so long as it drops to 1 when the beam is blocked.
- For an application where material is introduced from above, a suitable delay time must be provided to avoid instantaneous detection of falling material.
- To use UNBLOCK output mode, switch the mode selection switch to UNBLOCK.