

MWS-ST

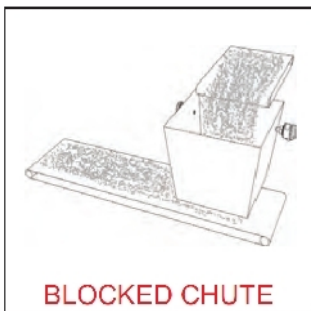

MICROWAVE TRANSMITTER
AND RECEIVER SENSORS

40



40

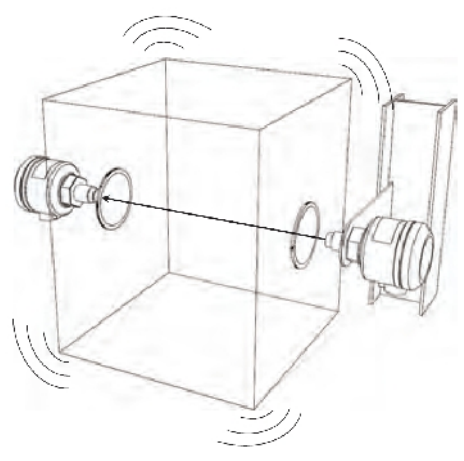
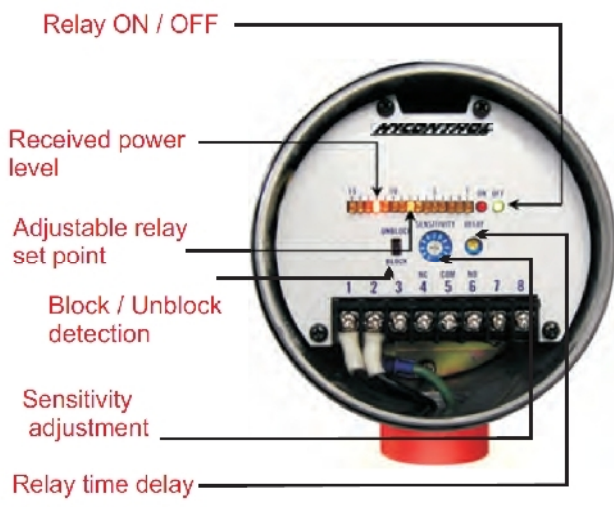

15-

STANDARD

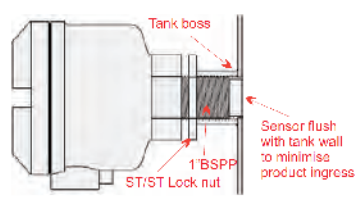

Standard 1" BSPP process connection directly into the tank socket. Suitable for low abrasion applications.

FLANGE

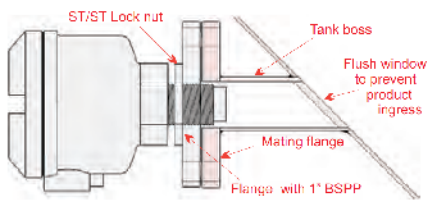

Flange with 1" BSPP process connection through a flange socket with Teflon window. The angle of the tank wall will have little or no effect on the transmitter.

FLANGE WITH INSERT

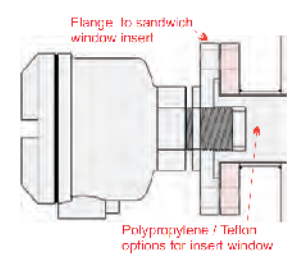

Flange process connection with optional polypropylene plug sandwiched between flanges but flush with tank wall. This provides additional sensor protection.

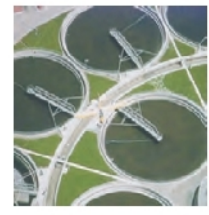

-
-
-
-
-

: HYC-MWC-MWS-ST-2-24V
: HYC-MWS-SR-2-24V

:
: 24 . ±10%
: 24 . ±10%

:
: 1 ,42
: 2 ,83

:
40 ()

24 GHz, 100mW (E.I.R.P)

:
15 ()

: 20 .
: 1 (SPDT) 30 . ,2

: 10
: 0,1-10

:
: 50
: 5
: -10-+55 ()

: -20 -+70

. : 5

: IP65

: : 1 : 1

EN300440-2, EN301489-1/3

TRANSMITTER AND RECEIVER SENSOR DIMENSIONS

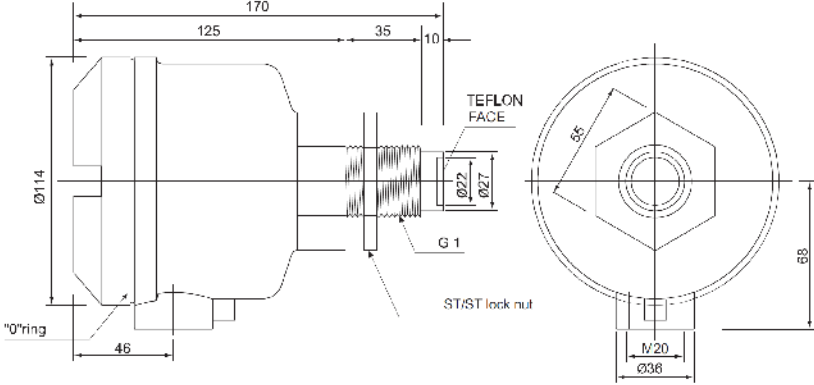

Dimensions may change without prior notice