

# F(C)D

.1

(

FCH).

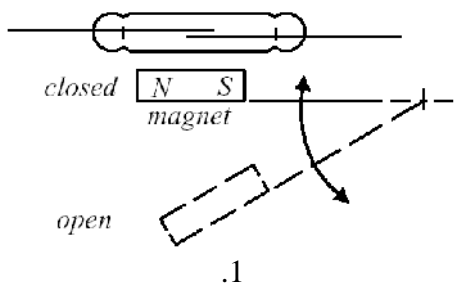

.2

(

FC V).

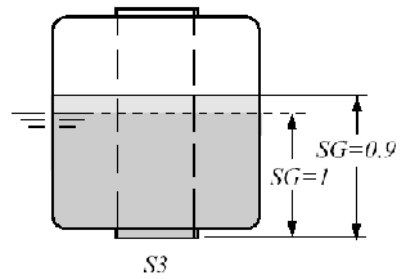
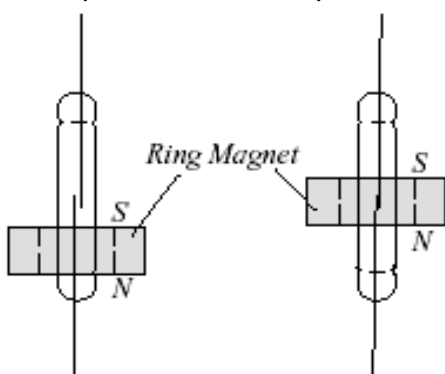

( )

2

( )

.3

● -

△ -

○ -

× -

| Chemical  | Concentration % | Temp |     | Plastic |    |      |      | Rubber | Stainless |     |
|---|-----------------|------|-----|---------|----|------|------|--------|-----------|-----|
|   |                 | °C   | °F  | PVC     | PP | PVDF | PTFE | NBR    | 304       | 316 |
| Ammonia Water<br>NH <sub>4</sub> OH                                       | 10              | 40   | 104 | ●       | ●  | ●    | ●    | ○      |           |     |
|   | 10              | 80   | 176 |         | ○  | ●    | ●    |        |           |     |
| Aque Regia<br>3HCl+HNO <sub>3</sub>                                       | 10              | 40   | 104 | △       | △  | ●    | ●    |        |           |     |
|   | 10              | 80   | 176 |         |    | ●    | ●    |        |           |     |
| Benzene<br>C <sub>6</sub> H <sub>6</sub>                                  | Pure            | 40   | 104 | ×       | △  | ○    | ●    |        |           |     |
|   |                 | 80   | 176 |         |    | △    | ●    |        |           |     |
| Bleaching Liquor<br>Ca(ClO) <sub>2</sub>                                  | 5               | 40   | 104 | ●       |    | ●    | ●    |        |           |     |
|   | 5               | 80   | 176 |         |    | ●    | ●    |        |           |     |
|   | 20              | 40   | 104 | ●       |    | ●    | ●    |        |           |     |
|   | 20              | 80   | 176 |         |    | ●    | ●    |        |           |     |
| Boric Acid<br>H <sub>3</sub> BO <sub>3</sub>                              | Satu            | 40   | 104 | ●       | ●  | ●    | ●    | ●      |           |     |
|   |                 | 80   | 176 |         | ●  | ●    | ●    | ○      |           |     |
| Brine   |                 | 40   | 104 | ●       | ●  | ●    | ●    | ●      |           |     |
|   |                 | 80   | 176 |         | ●  | ●    | ●    |        |           |     |
| Butadiene<br>CH <sub>2</sub> =CH=CH=CH <sub>2</sub>                       | Gas             | 40   | 104 | ●       |    | ●    | ●    |        |           |     |
|   |                 | 80   | 176 |         |    | ●    | ●    |        |           |     |
| Butane<br>CH <sub>3</sub> (CH <sub>2</sub> ) <sub>2</sub> CH <sub>3</sub> | Gas             | 40   | 104 | ●       | ●  | ●    | ●    |        |           |     |
|   |                 | 80   | 176 |         | ●  | ●    | ●    |        |           |     |
| Nitric Acid<br>HNO <sub>3</sub>   | 10              | 40   | 104 | ●       | ●  | ●    | ●    | ●      | ●         | ●   |
|   | 10              | 80   | 176 | ×       | ○  | ●    | ●    |        | ●         |     |
|   | 30              | 40   | 104 | ●       | ●  | ●    | ●    |        | ●         | ●   |
|   | 30              | 80   | 176 | ×       | ○  | ●    | ●    |        | ●         | ●   |
|   | 50              | 40   | 104 | ○       | ○  | ●    | ●    |        | ●         | ●   |
|   | 50              | 80   | 176 | ×       | ×  | ○    | ●    |        |           |     |
|   | 70              | 40   | 104 | ○       | ×  | ●    | ●    |        | ○         | ●   |
|   | 70              | 80   | 176 | ×       |    | ○    | ●    |        |           |     |
|   | 98              | 40   | 104 |         |    | ○    | ○    |        |           |     |
|   | 98              | 80   | 176 |         |    |      | △    |        |           |     |
| Oxalic Acid<br>HOOCOOH  | 20              | 40   | 104 | ●       | ●  | ●    | ●    | ●      |           | △   |
|   | 20              | 80   | 176 |         | ●  | ●    | ●    |        |           |     |
|   | 50              | 40   | 104 | ●       | ●  | ●    | ●    |        |           | △   |
|   | 50              | 80   | 176 |         | ●  | ●    | ●    |        |           |     |
| Phosphoric Acid<br>H <sub>3</sub> PO <sub>4</sub>                         | 10              | 40   | 104 | ●       | ●  | ●    | ●    | ●      | ●         | ●   |
|   | 10              | 80   | 176 |         | ○  | ●    | ●    | △      | ●         | ●   |
|   | 50              | 40   | 104 | ●       | ●  | ●    | ●    | ●      | ●         | ●   |
|   | 50              | 80   | 176 |         | △  | ●    | ●    | ×      | ●         | ●   |
|   | 80              | 40   | 104 | ●       | ●  | ●    | ●    | ○      | ●         | ●   |
|   | 80              | 80   | 176 |         | △  | ●    | ●    |        | ●         | ●   |
| Butane<br>CH <sub>3</sub> (CH <sub>2</sub> ) <sub>2</sub> CH <sub>3</sub> | Gas             | 40   | 104 | ●       | ●  | ●    | ●    |        |           |     |
|   |                 | 80   | 176 |         | ●  | ●    | ●    |        |           |     |
| Sodium Hydroxide<br>NaOH  | 15              | 40   | 104 | ●       | ●  | ●    | ●    | ●      | ●         | ●   |
|   | 15              | 80   | 176 |         | ○  | △    | ●    | △      | ×         | ×   |
|   | 30              | 40   | 104 | ●       | ●  | ●    | ●    | ●      | ●         | ●   |
|   | 30              | 80   | 176 |         | ○  | △    | ●    | ●      | ×         | ×   |
|   | 50              | 40   | 104 | ●       | ●  | ○    | ●    | ●      | ●         | ●   |
|   | 50              | 80   | 176 |         | ○  | ×    | ●    | ●      | ×         | ×   |
|   | 70              | 40   | 104 | ○       | ○  | ○    | ●    |        |           |     |
|   | 70              | 80   | 176 |         | ○  | ×    | ●    |        |           |     |

chemical –  
 rubber –  
 ammonia water –  
 sodium hydroxide –  
 leaching liquor -  
 boric acid –  
 brine –  
 phosphoric acid -

concentration –  
 stainless -  
 benzene –  
 butadiene –  
 butane –  
 nitric acid –  
 oxalic acid –  
 sodium hypochlorite -

temp. -  
 sulfuric acid –  
 toluene -  
 chlorine gas –  
 chromic acid -  
 hydrochloric acid –

| Chemical   | Concentration % | Temp                            |     | Plastic |     |      |      | Rubber | Stainless |     |  |  |
|--|-----------------|---------------------------------|-----|---------|-----|------|------|--------|-----------|-----|--|--|
|  |                 | °C                              | °F  | PVC     | PP  | PVDF | PTFE | NBR    | 304       | 316 |  |  |
| Sodium Hypochlorite<br>NaClO                             | 3               | 40                              | 104 | ●       | ○   | ●    | ●    |        | △         | ○   |  |  |
|  | 3               | 80                              | 176 |         |     |      |      |        |           |     |  |  |
|  | 5               | 40                              | 104 | ●       | ○   | ●    | ●    |        | △         | ○   |  |  |
|  | 5               | 80                              | 176 |         |     |      |      |        |           |     |  |  |
|  | 7               | 40                              | 104 | ●       | △   | ○    | ●    |        | ×         | ×   |  |  |
|  | 7               | 80                              | 176 |         |     |      |      |        |           |     |  |  |
|  | 10              | 40                              | 104 | ●       | △   | ●    | ●    |        | ×         | ×   |  |  |
|  | 10              | 80                              | 176 |         |     |      |      |        |           |     |  |  |
| Sulfuric Acid<br>H <sub>2</sub> SO <sub>4</sub>          | 10              | 40                              | 104 | ●       | ●   | ●    | ●    | ●      | ●         | ●   |  |  |
|  | 10              | 80                              | 176 |         | ●   | ●    | ●    | ○      | ○         | ○   |  |  |
|  | 30              | 40                              | 104 | ●       | ●   | ●    | ●    | ●      | ×         | ×   |  |  |
|  | 30              | 80                              | 176 |         | ●   | ●    | ●    | ○      | ×         | ×   |  |  |
|  | 50              | 40                              | 104 | ●       | ●   | ●    | ●    | ○      | ×         | ×   |  |  |
|  | 50              | 80                              | 176 |         | ●   | ●    | ●    | △      | ×         | ×   |  |  |
|  | 60              | 40                              | 104 | ●       | ●   | ●    | ●    | ●      | ×         | ×   |  |  |
|  | 60              | 80                              | 176 |         | ○   | ●    | ●    | ○      | ×         | ×   |  |  |
|  | 70              | 40                              | 104 | ●       | ●   | ●    | ●    | ○      | ×         | ×   |  |  |
|  | 70              | 80                              | 176 |         | ○   | ●    | ●    | △      | ×         | ×   |  |  |
| Toluene<br>C <sub>6</sub> H <sub>5</sub> CH <sub>3</sub> |                 | 40                              | 104 |         |     |      |      |        |           |     |  |  |
|  |                 | 80                              | 176 |         |     |      |      |        |           |     |  |  |
|  |                 | 40                              | 104 |         | △   | △    | ●    |        |           |     |  |  |
|  |                 | 80                              | 176 |         |     |      | ○    |        |           |     |  |  |
|  |                 | Chlorine Gas<br>Cl <sub>2</sub> | Wet | 40      | 104 | ○    |      | ●      | ●         |     |  |  |
|  |                 |                                 |     | 80      | 176 |      |      | △      | ●         |     |  |  |
|  |                 |                                 | Dry | 40      | 104 | ●    |      | ●      | ●         |     |  |  |
|  |                 |                                 |     | 80      | 176 |      |      | ●      | ●         |     |  |  |
| Chromic Acid<br>H <sub>2</sub> CrO <sub>4</sub>          | 10              | 40                              | 104 | ●       |     | ●    | ●    |        |           |     |  |  |
|  | 10              | 80                              | 176 |         |     | ●    | ●    |        |           |     |  |  |
|  | 20              | 40                              | 104 | △       |     | ●    | ●    |        |           |     |  |  |
|  | 20              | 80                              | 176 |         |     | ●    | ●    |        |           |     |  |  |
|  | 40              | 40                              | 104 | △       |     | ●    | ●    |        |           |     |  |  |
|  | 40              | 80                              | 176 |         |     | ●    | ●    |        |           |     |  |  |
|  | 50              | 40                              | 104 | ×       |     | ●    | ●    |        |           |     |  |  |
|  | 50              | 80                              | 176 |         |     | △    | ●    |        |           |     |  |  |
| Hydrochloric Acid<br>HCl                                 | 15              | 40                              | 104 | ●       | ●   | ●    | ●    | ○      |           |     |  |  |
|  | 15              | 80                              | 176 |         | ●   | ●    | ●    |        |           |     |  |  |
|  | 25              | 40                              | 104 | ●       | ●   | ●    | ●    | ×      |           |     |  |  |
|  | 25              | 80                              | 176 |         | ●   | ●    | ●    |        |           |     |  |  |
|  | 35              | 40                              | 104 | ●       | ●   | ●    | ●    | ×      |           |     |  |  |
|  | 35              | 80                              | 176 |         | ○   | ●    | ●    |        |           |     |  |  |
|  | 38              | 40                              | 104 | ●       | ●   | ●    | ●    | ×      |           |     |  |  |
|  | 38              | 80                              | 176 |         | ○   | ●    | ○    |        |           |     |  |  |

● Excellent ○ Good △ Fair × Corroded

| Chemical                                | Concentration<br>% | Temp |     | Plastic |    |      |      | Rubber |     | Stainless |  |
|---|--------------------|------|-----|---------|----|------|------|--------|-----|-----------|--|
|   |                    | °C   | °F  | PVC     | PP | PVDF | PTFE | NBR    | 304 | 316       |  |
| Citric Acid<br>$C_6H_8O_7$              | 10                 | 40   | 104 | ●       | ●  | ●    | ●    | ●      | ●   | ●         |  |
|   | 10                 | 80   | 176 |         | ○  | ●    | ●    | ●      |     |           |  |
| Gasoline                                | 10                 | 40   | 104 | ●       |    | ●    | ●    |        |     |           |  |
|   | 10                 | 80   | 176 |         |    | ●    | ●    |        |     |           |  |
| Diesel Fuels                            |                    | 40   | 104 |         |    | ●    | ●    |        | ●   | ●         |  |
|   |                    | 80   | 176 |         |    | ●    | ●    |        | ●   | ●         |  |
| Ethyl Alcohol<br>$C_2H_5OH$             | Pure               | 40   | 104 | ●       | ●  | ●    | ●    | ●      | ○   | ○         |  |
|   |                    | 80   | 176 |         | ○  | ●    | ●    | ○      |     |           |  |
| Formic Acid<br>$HCOOH$                  | 90                 | 40   | 104 | ○       | ○  | ●    | ●    |        |     |           |  |
|   |                    | 80   | 176 |         |    | ●    | ●    |        |     |           |  |
| Hydrofluoric<br>Acid<br>$HF$            | Dilute             | 40   | 104 | ●       | ○  | ●    | ●    |        |     |           |  |
|   |                    | 80   | 176 |         | ○  | ●    | ●    |        |     |           |  |
|   | Dilute             | 30   | 40  | 104     | ○  | ○    | ●    | ●      |     |           |  |
|   |                    | 30   | 80  | 176     | ×  | ○    | ●    | ●      |     |           |  |
|   |                    | 40   | 40  | 104     | △  | ○    | ●    | ●      |     |           |  |
|   |                    | 40   | 80  | 176     |    | ○    | ●    | ●      |     |           |  |
|   |                    | 50   | 40  | 104     | △  | ○    | ●    | ●      |     |           |  |
|   |                    | 50   | 80  | 176     |    | ○    | ●    | ●      |     |           |  |
| Hydrogen<br>peroxide<br>$H_2O_2$        | 5                  | 40   | 104 | ●       | ●  | ●    | ●    |        | ○   | ●         |  |
|   | 5                  | 80   | 176 |         | ○  | ●    | ●    |        |     |           |  |
|   | 20                 | 40   | 104 | ●       | ●  | ●    | ●    |        |     |           |  |
|   | 20                 | 80   | 176 |         | ○  | ●    | ●    |        |     |           |  |
|   | 30                 | 40   | 104 | ○       | ○  | ●    | ●    |        |     |           |  |
|   | 30                 | 80   | 176 |         | △  | ●    | ●    |        |     |           |  |
|   | 50                 | 40   | 104 | △       | ×  | ●    | ●    |        |     |           |  |
|   | 50                 | 80   | 176 |         |    | ●    | ●    |        |     |           |  |
|   | 90                 | 40   | 104 |         |    | ●    | ●    |        |     |           |  |
|   | 90                 | 80   | 176 |         |    | ●    | ●    |        |     |           |  |
| Isopropyl Alcohol<br>$(CH_3)_2CHOH$     | Pure               | 40   | 104 | ●       | ●  | ●    | ●    | ○      |     |           |  |
|   |                    | 80   | 176 |         |    | ●    | ●    |        |     |           |  |
| Kerosene                                |                    | 40   | 104 | ●       | ○  | ●    | ●    |        |     |           |  |
|   |                    | 80   | 176 |         |    | ●    | ●    |        |     |           |  |
| Methyl Alcohol<br>$CH_3OH$              |                    | 40   | 104 | ○       | ●  | ●    | ●    | △      |     |           |  |
|   |                    | 80   | 176 |         | ○  | ●    | ●    |        |     |           |  |
| Methyl Ethyl Ketone<br>$CH_3COCH_2CH_3$ |                    | 40   | 104 |         | △  |      | ●    |        |     |           |  |
|   |                    | 80   | 176 |         |    |      | ●    |        |     |           |  |
| Potassium Chromate<br>$K_2CrO_4$        |                    | 40   | 104 | ●       | ●  | ●    | ●    | ●      |     |           |  |
|   |                    | 80   | 176 |         | ○  | ●    | ●    | ○      |     |           |  |

citric acid –  
 gasoline -  
 diesel fuels –  
 ethyl alcohol –  
 formic acid -  
 hydrofluoric acid -  
 hydrogen peroxide -  
 isopropyl alcohol -  
 kerosene -  
 methyl alcohol –  
 methyl ethyl ketone -  
 potassium chromate -

■  
 ,  
 ,  
 ,  
 ( . . . ) .  
 ,  
 RC ( . . . ) .  
 4b, 4c)

$$C = \frac{I^2}{10} \text{ (uF)}$$

$$R = \frac{E}{10I(1 + \frac{E}{50})}$$

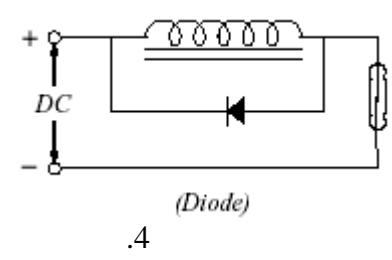
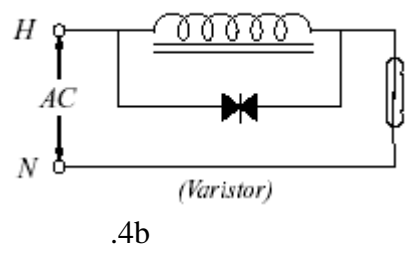
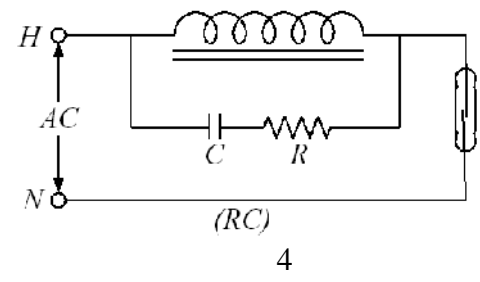

5b). ( . . . ) .5 ,

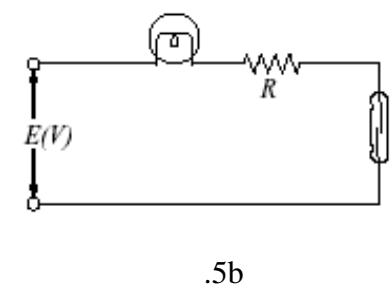
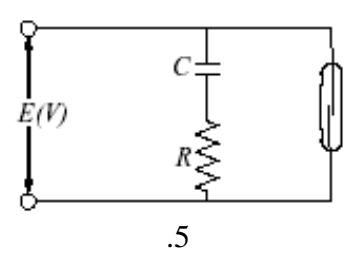

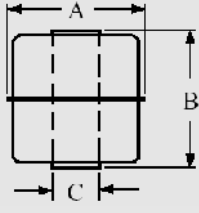
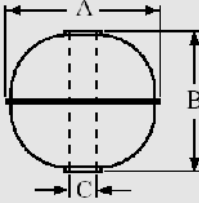
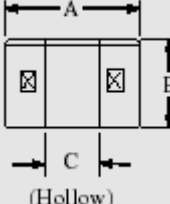
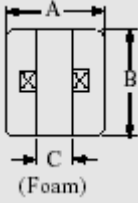
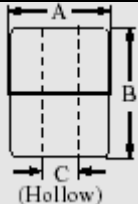
|   |    | Ø Ø Ø      |        | ( / ²) | ( )  | /      | ( ° ) |
|---|----|------------|--------|--------|------|--------|-------|
|                | S1 | 28x28x9.5  | E>0,8  | 10     | 8    | SUS316 | 200   |
|   | S3 | 45x55x15   | E>0,65 | 12     | 36   | SUS316 | 200   |
|   | S6 | 75x108x19  | E>0,5  | 10     | 145  | SUS304 | 200   |
|                | S2 | 41x38x11   | E>0,7  | 35     | 19   | SUS316 | 200   |
|   | S4 | 52x52x15   | E>0,55 | 30     | 33   | SUS316 | 200   |
|   | S5 | 75x73x19   | E>0,55 | 30     | 103  | SUS304 | 200   |
|   | S7 | 30x28x9.5  | E>0,68 | 30     | 7    | SUS316 | 200   |
| <br>(Hollow)  | P1 | 25x15x10   | E>0,8  | 4      | 4    | /      | 80    |
|   | P2 | 25x25x10   | E>0,7  | 4      | 5    | /      | 80    |
|   | P3 | 48x45x18.5 | E>0,6  | 4      | 37   | /      | 80    |
|   | P4 | 20x25x10   | E>0,8  | 4      | 5    | /      | 80    |
|   | P5 | 20x20x8.1  | E>0,8  | 4      | 4    | /      | 80    |
|   | P8 | 18x15x18   | E>0,8  | 4      | 7,5  | /      | 80    |
| <br>(Foam)   | Q6 | 20 20 7,5  | E>0,8  |        | 3,5  | NBR    | 100   |
|   | Q7 | 25 25 10   | E>0,8  |        | 6,5  | NBR    | 100   |
|   | N1 | 25 15 10   | E>0,8  |        | 4,5  | NBR    | 100   |
|   | N2 | 18,5 26 10 | E>0,8  |        | 2,6  | NBR    | 100   |
|   | N3 | 19 20 10   | E>0,8  |        | 2,4  | NBR    | 100   |
|   | N4 | 17,5 25 10 | E>0,8  |        | 2,4  | NBR    | 100   |
|   | N5 | 30 45 10   | E>0,5  |        | 11,3 | NBR    | 100   |
| <br>(Hollow) | F2 | 42x44x14   | E>0,8  | 5      | 20   | PP     | 80    |
|   | F3 | 45x45x20   | E>0,5  | 5      | 25   | PP     | 80    |
|   | F4 | 48x70x18   | E>0,8  | 5      | 65   | PVDF   | 120   |

► FD MH16

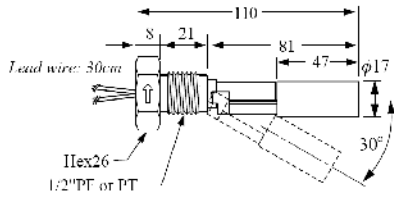

► FD MH16A (MH16R+Adapter)

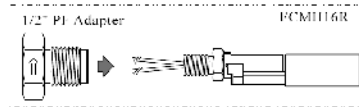
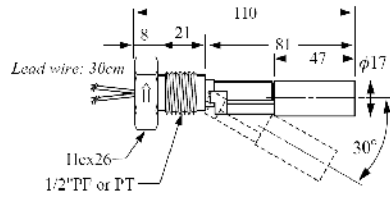
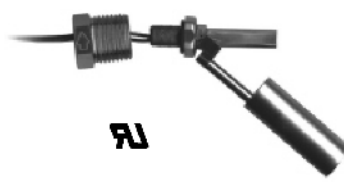

► FD MH16C

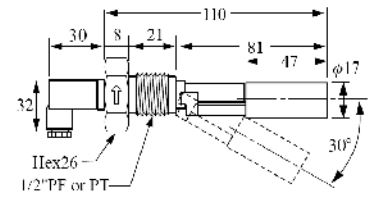

► FD MH16R

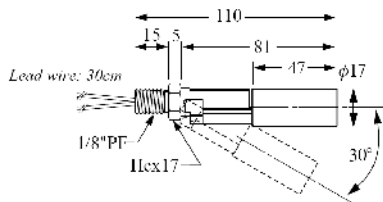

► FD MH26

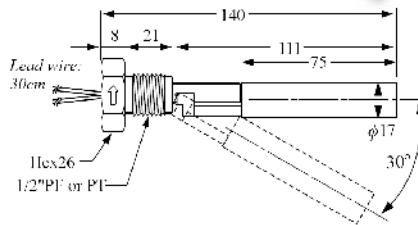

► FD MH16D

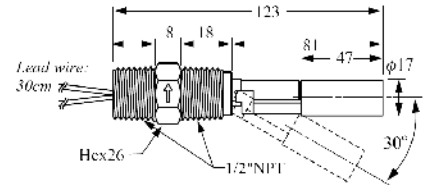

■ SPECIFICATIONS

|                             |        |              |            |     |   |                |          |                       |            |
|-----------------------------|--------|--------------|------------|-----|---|----------------|----------|-----------------------|------------|
|                             |        |              |            |     |   |                |          |                       |            |
| FDMH16<br>A/C/D/R<br>FDMH26 | SUS304 | 50B/<br>SPST | 240<br>200 | 0,5 | 1 | XLPE<br>TEFLON | 5<br>/ 2 | -20~120°<br>( .200° ) | 0,8<br>0,7 |



▶ FC H21PD / H31PD



FCH2 FCH3

, PVDF.

.10.

FC H21 PD ( )

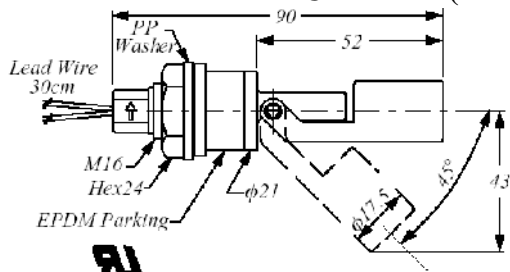

PP washer –  
Lead wire –  
Hex –  
EPDM parking –

Arrow Downward  
Normally Closed

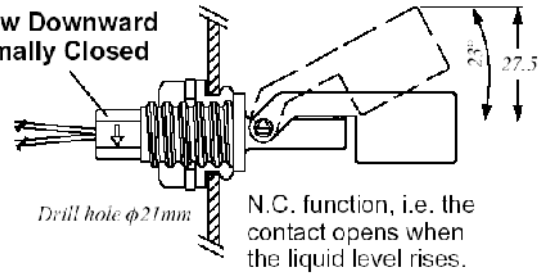

FC H21 PD

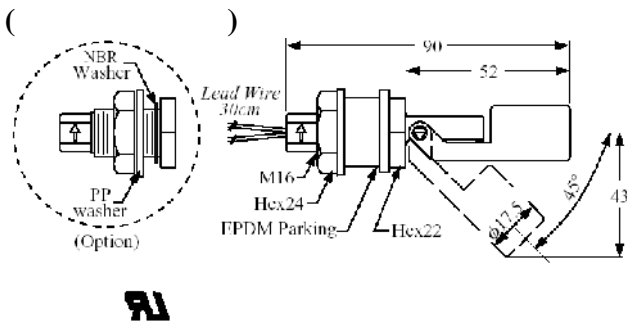

Arrow Upward  
Normally Open

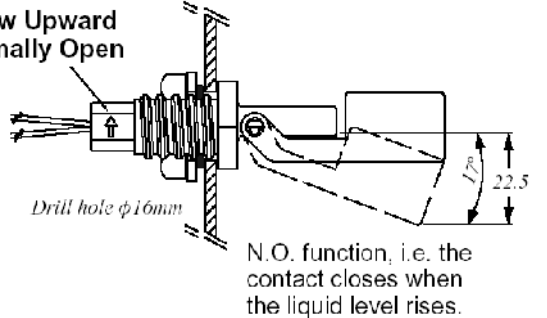

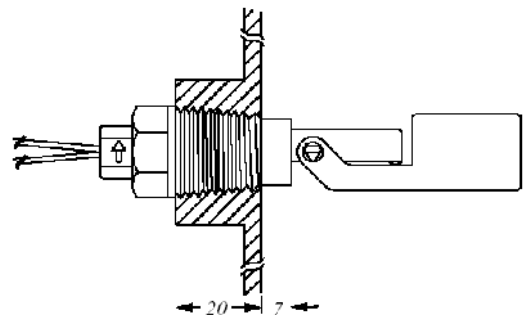
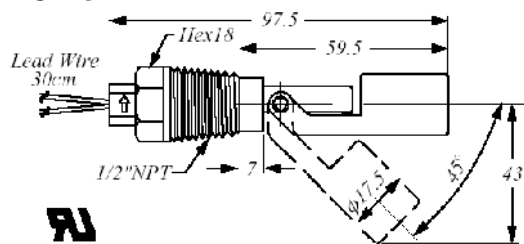

FC H31 PD

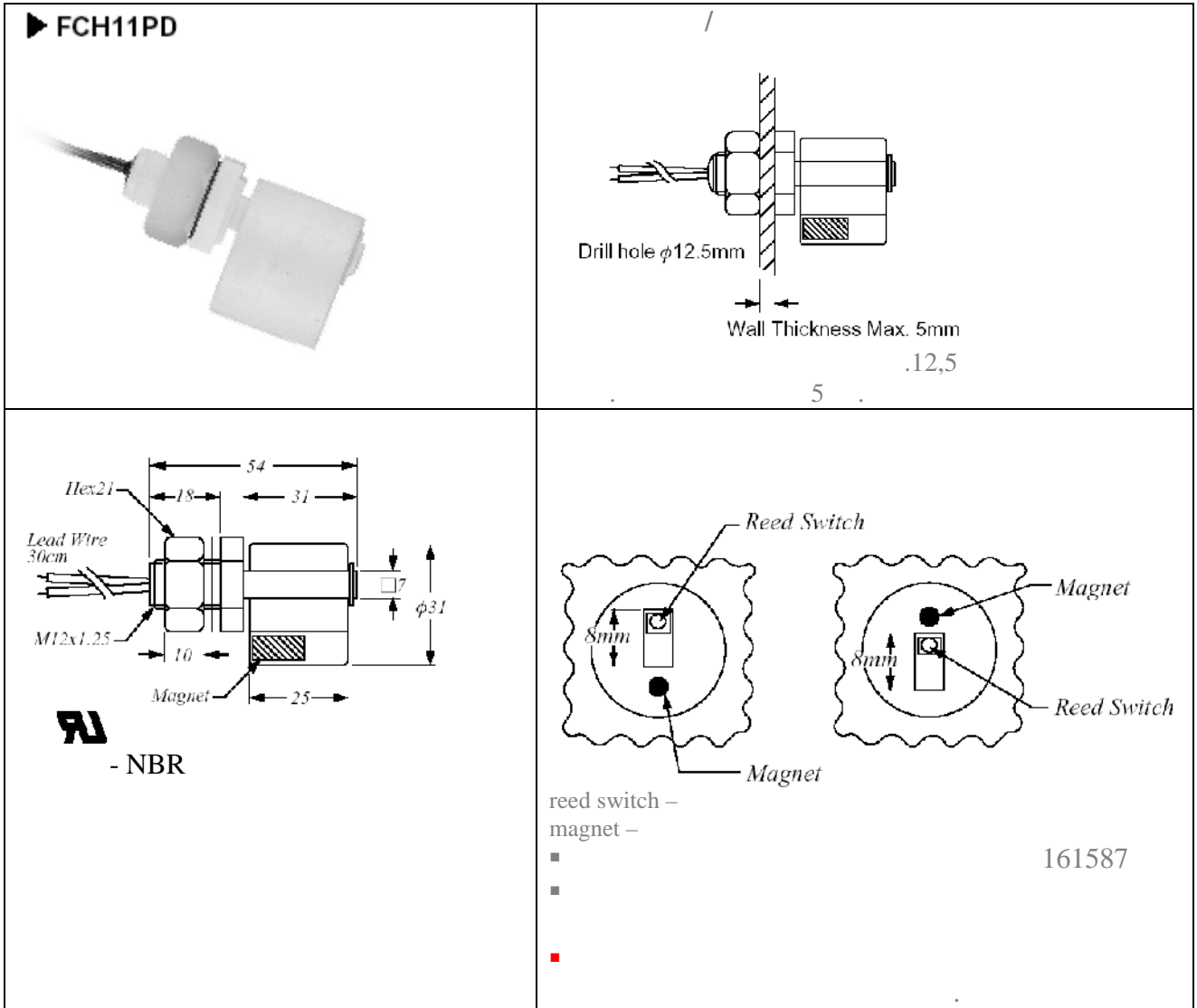



|  | FCH11PD   | FCH21PD<br>FCH31PD   | FCH23FD<br>FCH33FD   | FCH24YD<br>FCH34YD | FCH25GD<br>FCH35GD |
|--|-----------|----------------------|----------------------|--------------------|--------------------|
|  | 50 SPST   |                      |                      |                    |                    |
|  | 240 / 200 |                      |                      |                    |                    |
|  | 0,5       |                      |                      |                    |                    |
|  | 1         |                      |                      |                    |                    |
|  | PVC AWG22 | XLPE AWG22           |                      |                    |                    |
|  | ATM       | 4 kg/cm <sup>2</sup> | 2 kg/cm <sup>2</sup> |                    |                    |
|  | -20~80°C  |                      | -20~120°C            |                    |                    |
|  | PP        |                      | PVDF                 |                    |                    |
|  | 0,78      | 0,75                 | 0,85                 | 0,8                | 0,85               |
|  | 25        | 21 22<br>31 21       | 25                   | 23                 | 25                 |

# OV

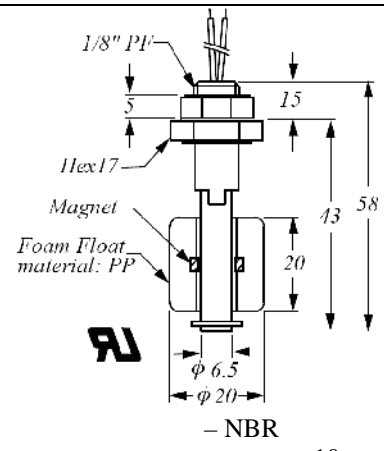
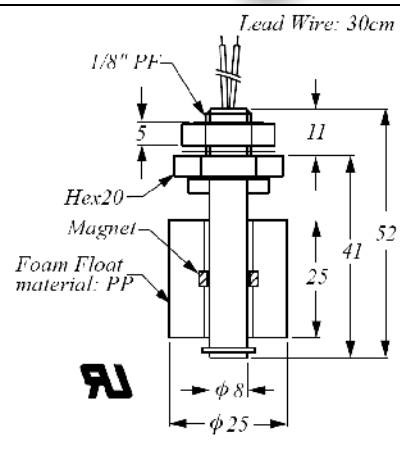
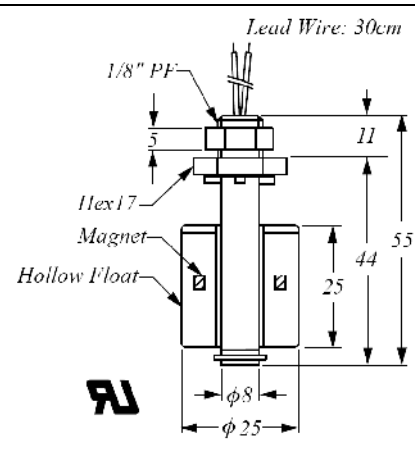
| ▶ FC V11QF   | ▶ FC V21QD   | ▶ FC V31PD 33FD, 34YD, 35GD   |
|--|--|---|
|   |   |    |
|  <p>1/8" PF<br/>5<br/>15<br/>Hex17<br/>Magnet<br/>Foam Float material: PP<br/>φ 6.5<br/>φ 20<br/>- NBR<br/>10</p> |  <p>Lead Wire: 30cm<br/>1/8" PF<br/>5<br/>11<br/>Hex20<br/>Magnet<br/>Foam Float material: PP<br/>φ 8<br/>φ 25<br/>- NBR<br/>10</p> |  <p>Lead Wire: 30cm<br/>1/8" PF<br/>5<br/>11<br/>Hex17<br/>Magnet<br/>Hollow Float<br/>φ 8<br/>φ 25<br/>: VITON<br/>10</p> |

|                    | FCV11QF           | FC V21QD | FC V31 PD            | FCV33D               | FC V34YD  | FCV35GD   |
|--------------------|-------------------|----------|----------------------|----------------------|-----------|-----------|
|                    | 10 SPST           | 50 SPST  | 50 SPST              |                      |           |           |
|                    | 125               | 240      | 240 / 200            |                      |           |           |
|                    | 250               |          | 200                  |                      |           |           |
| ( )                | 0,5               |          | 0,5                  |                      |           |           |
| ( )                | 1                 |          | 1                    |                      |           |           |
|                    | UL 1007 AWG22 PVC |          | UL 1007 AWG22 PVC    | XLPE AWG22           |           |           |
| ( / <sup>2</sup> ) | ATM               |          | 4 kg/cm <sup>2</sup> | 2 kg/cm <sup>2</sup> |           |           |
|                    | -20~80°C          |          | -20~80°C             | -20~120°C            | -20~110°C | -20~120°C |
|                    | PP                |          | PP                   | PVDF                 | -         |           |
|                    | 0,8               |          | 0,7                  | 0,85                 | 0,8       | 0,85      |
|                    | 12                | 18       | 15                   |                      |           |           |

OV

► FC V12NF

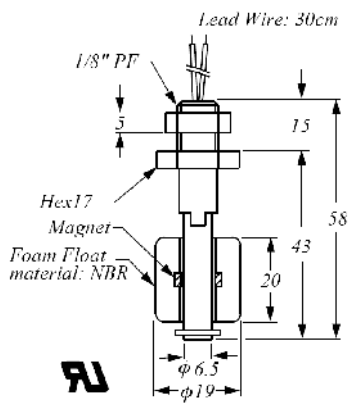

10

► FC V41PD, V41QD

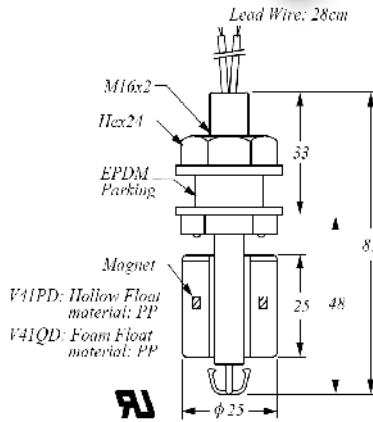

16

► FC V61PF, V61NF

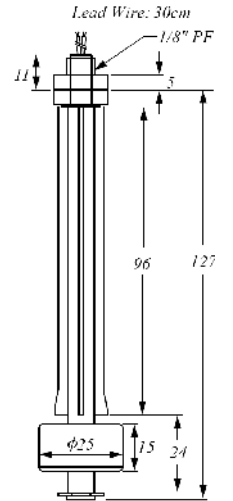

RU  
 V61PF:

V61NF:

NBR  
 : NBR

8,5

► FC V81PD

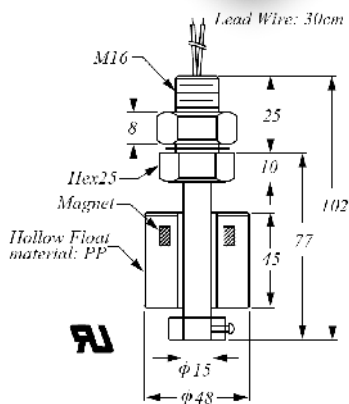
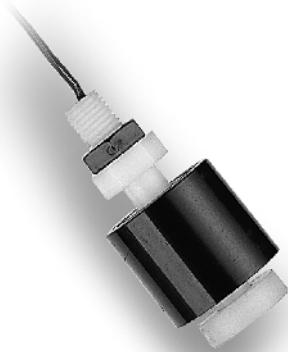

16

► FC V41ND

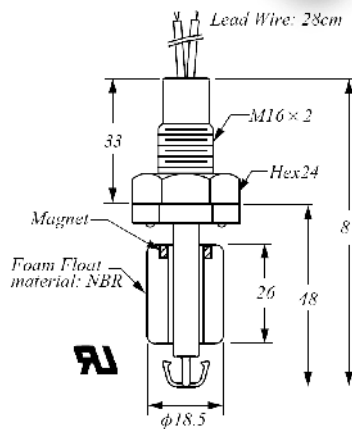
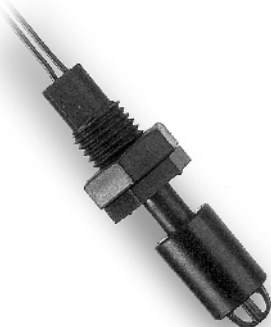

16

► FC V51PD

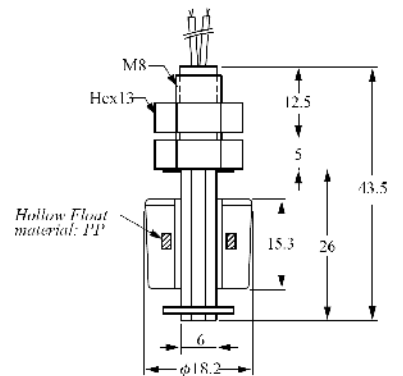

8.5

# OV

|          | FC V11NF               | FC V61PF<br>FC V61NF    | FC V41PD<br>FC V41QD<br>FC V41ND | FC V81PD | FC V41ND    | FC V51PD   |
|----------|------------------------|-------------------------|----------------------------------|----------|-------------|------------|
| •        | 10 SPST                |                         | 50 SPST                          |          |             |            |
| •        | 125                    | -                       | 240 /                            |          |             |            |
| •        | -                      | 250                     | 200                              |          |             |            |
| •<br>( ) | 0,5                    |                         |                                  |          |             |            |
| ( )      | 1                      |                         |                                  |          |             |            |
|          | XLPE AWG22             | UL 1007 AWG22 PVC       |                                  |          | XLPE AWG22  |            |
| ( / 2)   | 2                      | V61C:4 / 2<br>V61C: ATM | V41P:4 / 2<br>V41Q: ATM          | 4        | ATM         | 4          |
|          | -20 ~ 100°C            | -20 ~ 80°C              |                                  |          | -20 ~ 100°C | -20 ~ 80°C |
|          | PP ( V11N, V61N, V41N: |                         |                                  |          | NBR)        |            |
|          | 0,8                    | 0,7-0,8                 |                                  | 0,6      | 0,8         | 0,8        |
|          | 12                     | 16                      | 23                               | 180      |             |            |

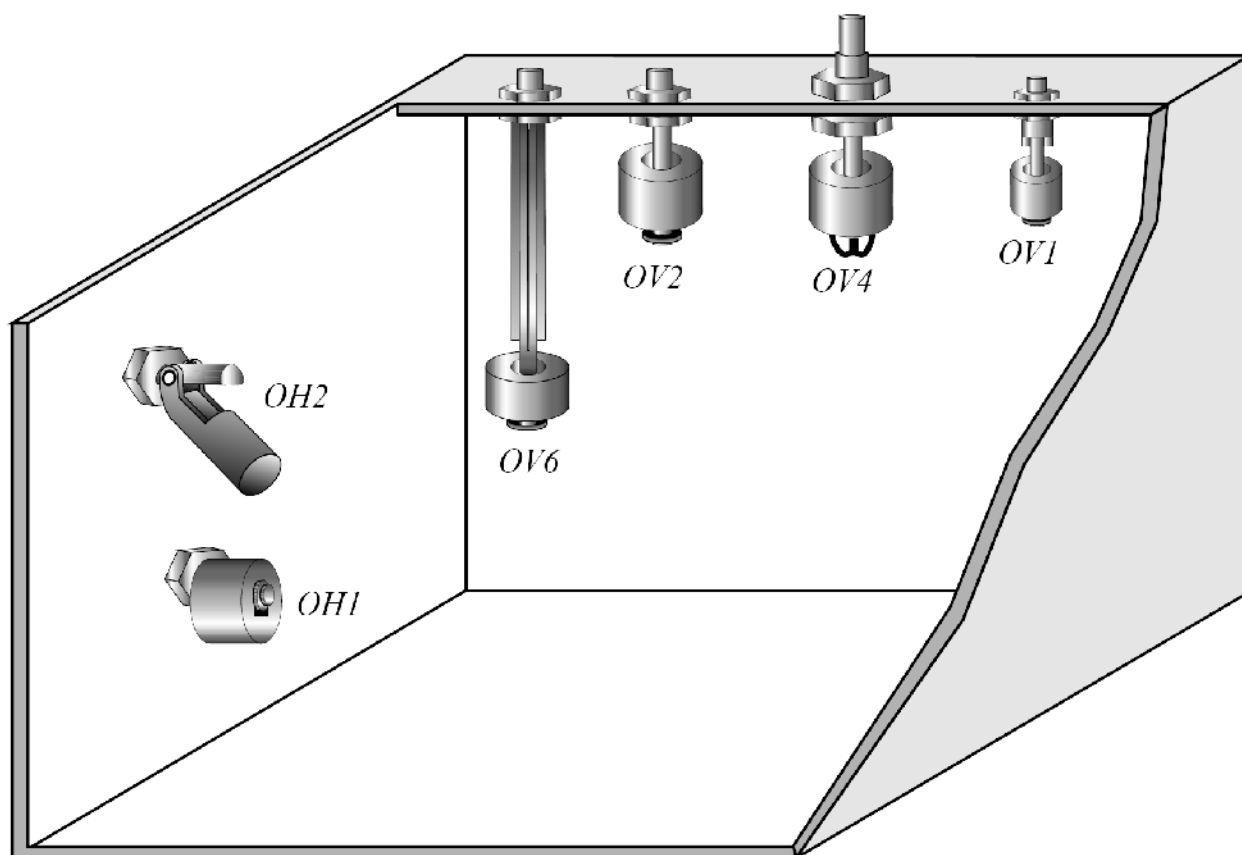

FC H1~H5: RF-OH  
 FC V1~V8: RF-OV

1: 4'  
 3: PVDF 5:

F: PVDF P: PP ( ) Y:  
 N: NBR Q: ( ) G:

D: 50 200 /240  
 F: 10 125 SPST  
 H: 3 30 / 60  
 ( FCV11 FCV61)  
 K: 20 150 / 200

: (N.O.) SPST  
 B: (N.C.) SPST  
 C: 1AB SPDT  
 D: NC  
 E: N

( . . =10 )  
 03: 30 ( ) \* FCV4 V5 28 .  
 05: 50  
 10: 100 (1 )  
 15: 150

C: PVC (80° ) - AWG22x2C x ø4  
 D: XLPVC (105°) - AWG22  
 F: (200° ) - AWG24x2C x ø4  
 P: PVC (80° ) - AWG22  
 S: (200° ) - AWG22  
 T: (200° ) - AWG24  
 X: XLPE (125° ) - AWG22

\* "A" ( ) -  
 7, 8, 10, 11 13.

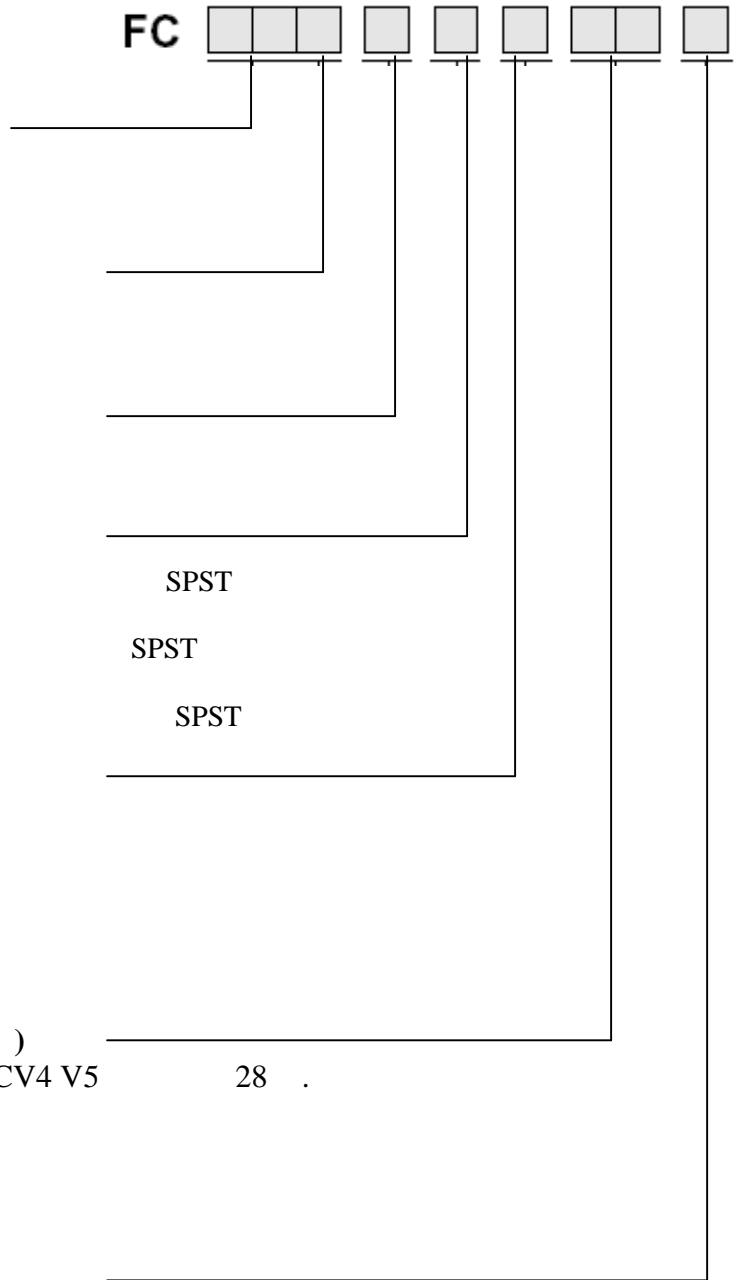

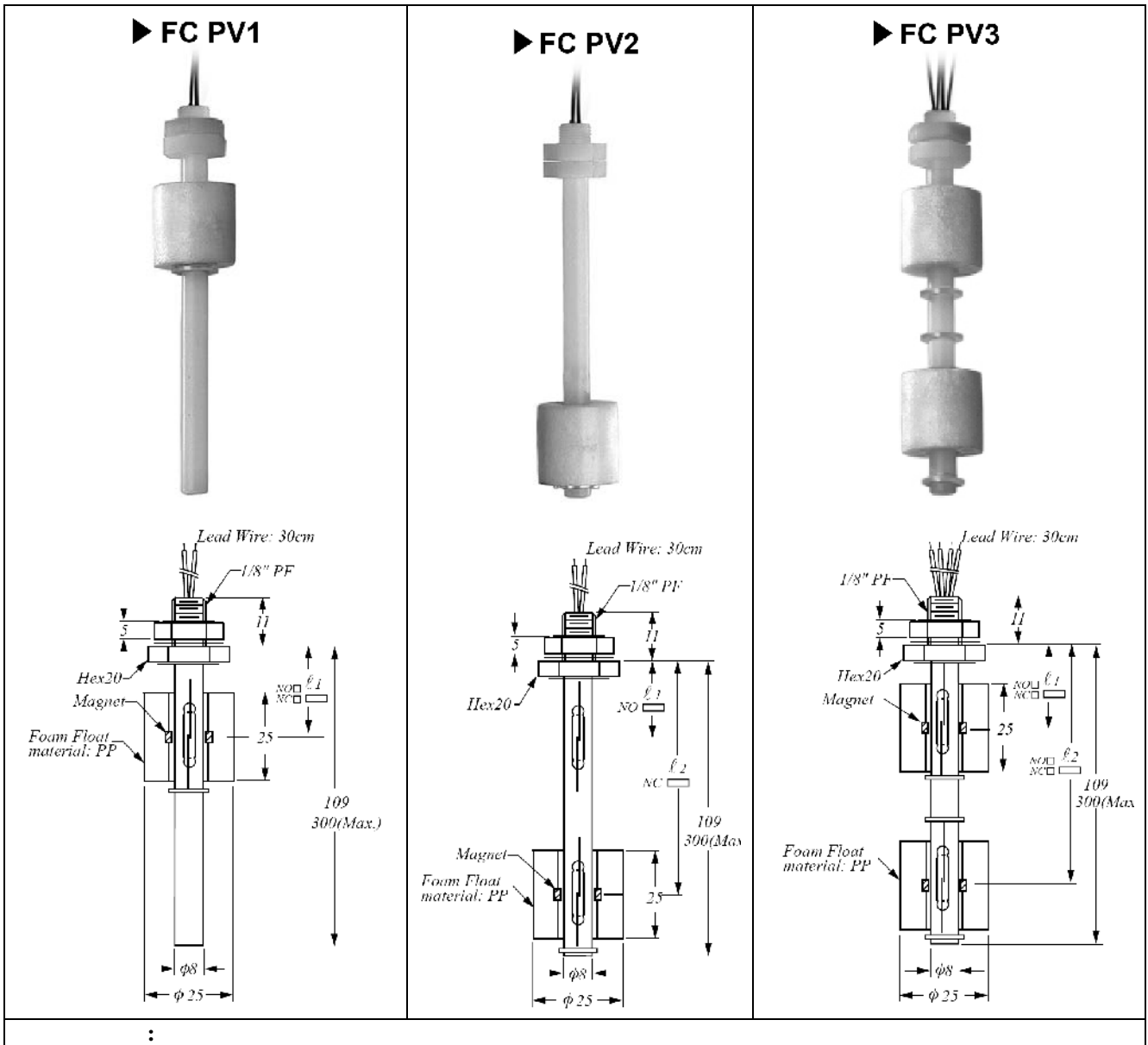

- PCPV1
- FCPV2
- FCPV3

FC PV1 2 D A 05 P

PV1: RF-PV1

PV2: RF-PV2

PV3: RF-PV3

1: , - PVC -  
 2: NBR ( );  
 3: PVDF; - XLPE -  
 4: ; - XLPE -

80°  
 - PVC - 60°  
 - XLPE - 100°  
 125°  
 125°

D: 50 200 /240  
 F: 10 125 SPST

SPST

: (N.O.) SPST  
 B: (N.C.) SPST

( . =10 )

03: 30 ( )  
 05: 50  
 15: 150  
 20: 200

P: PVC (80° )  
 X: XLPE (125° )

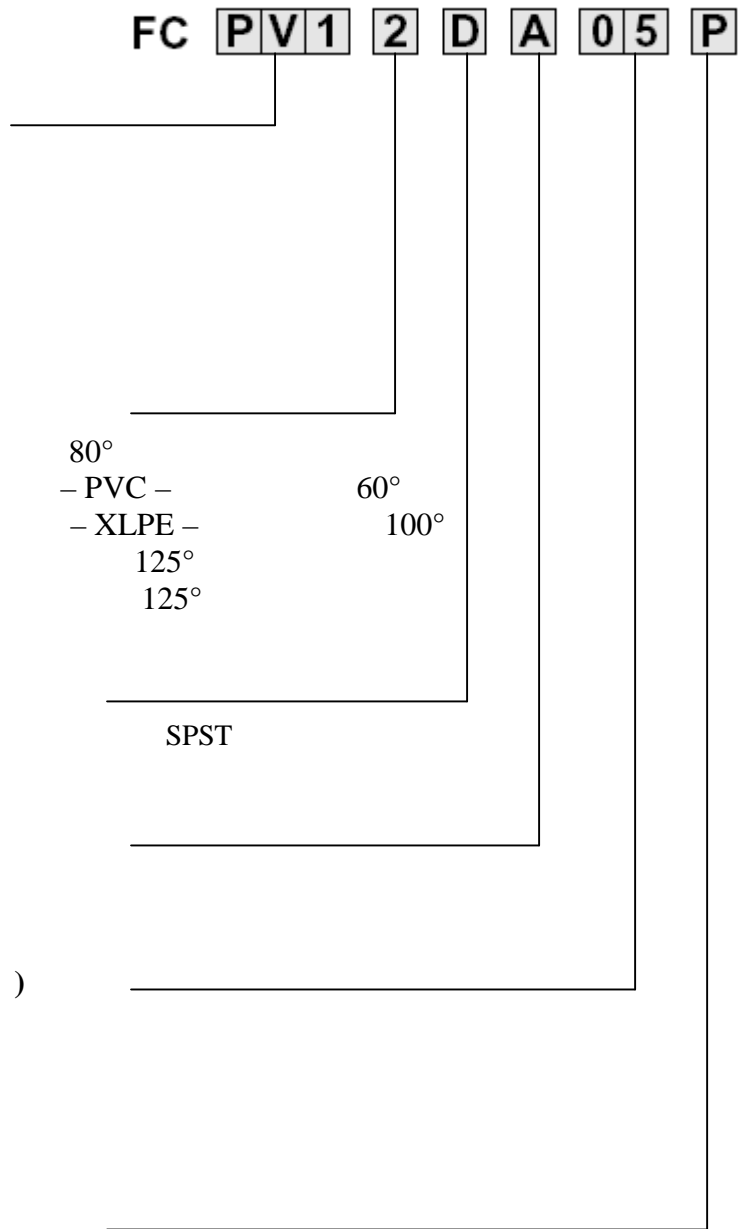

► FD 30□1/ FD 35□1

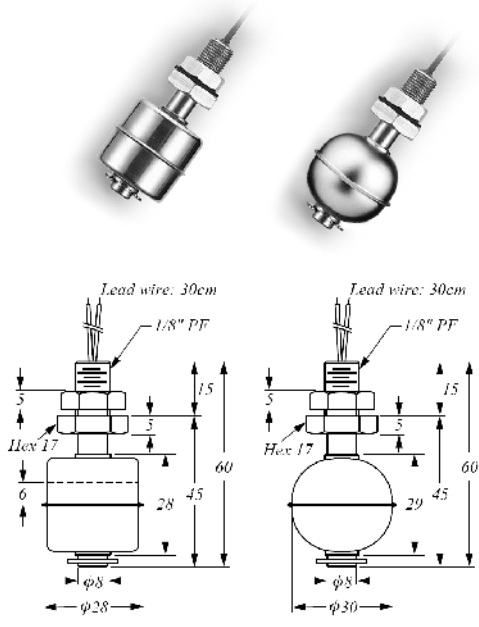

**RU** Drill hole φ10mm

► FD 40□1

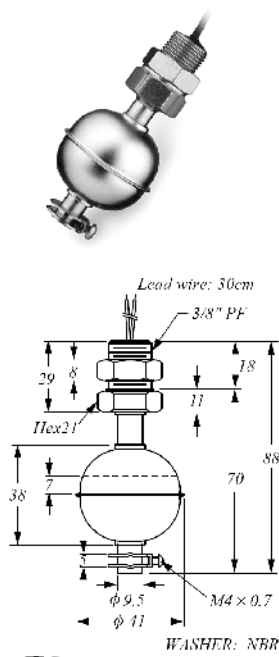

**RU** Drill hole φ17mm

► FD 45□1

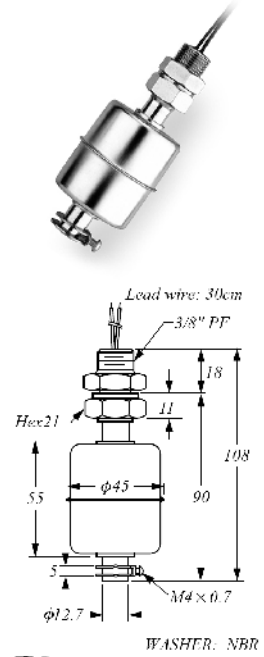

**RU** Drill hole φ17mm

► FD 30□2

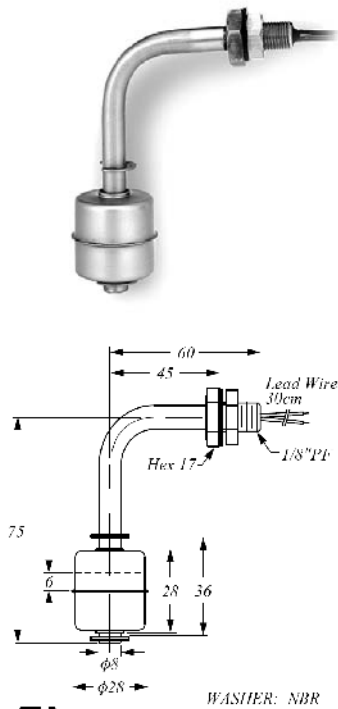

**RU** Drill hole φ10mm

► FD 40□2

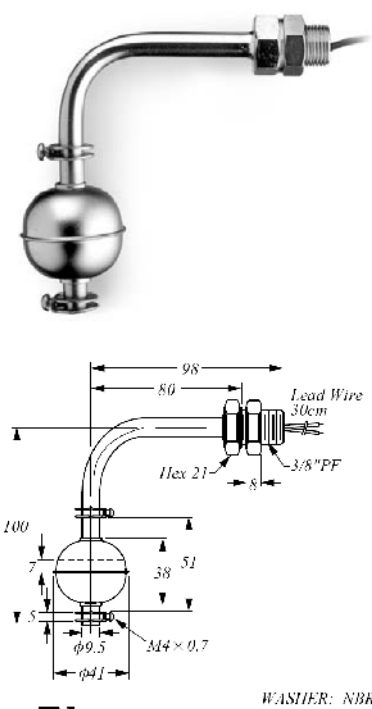

**RU** Drill hole φ17mm

► FD 45□2

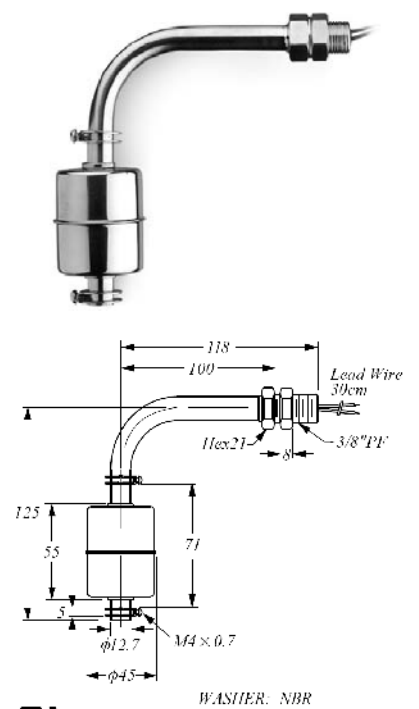

**RU** Drill hole φ17mm

► FD 50□1



WASHER: NBR

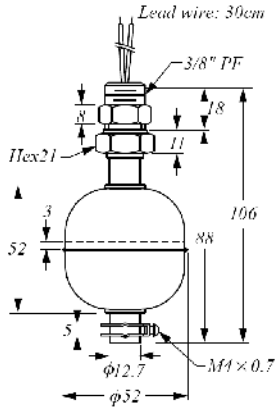

Drill hole φ17mm

► FD 50□2



WASHER: NBR

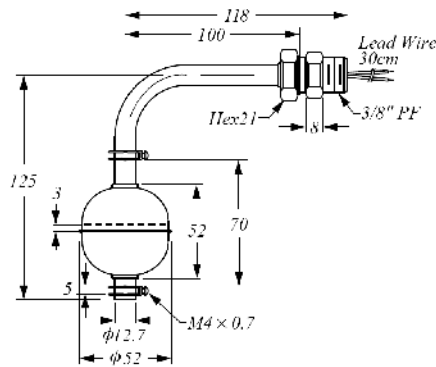

Drill hole φ17mm

► FD 75□1

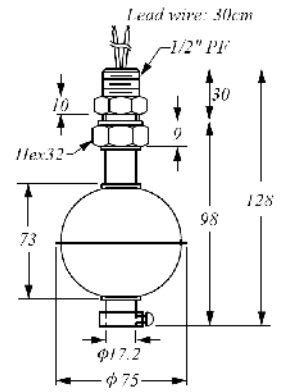

Drill hole φ21mm

|        | FD30□1D<br>FD30□2D       | FD40□1D<br>FD40□2D | FD45□1D<br>FD45□2D | FD50□1D<br>FD50□2D | FD75□1G | FD10□1G |
|--------|--------------------------|--------------------|--------------------|--------------------|---------|---------|
| .      | 50 SPST                  | 50 SPST            | 50 SPST            | 50 SPST            | 60 SPST |         |
| .      | 240 /                    |                    |                    | 200                |         |         |
| .      | 0,5                      | 0,5                | 0,5                | 0,5                | 2       |         |
| ( )    | 1                        | 1                  | 1                  | 1                  | 3       |         |
|        | XLPE (UL3266, AWG22)     |                    |                    |                    |         |         |
| ( / 2) | 10                       | 30                 | 12                 | 30                 | 30      | 10      |
|        | -10~120°C (OPTION 200°C) |                    |                    |                    |         |         |
|        | SUS304, 316              |                    |                    |                    |         |         |
|        | 0,8                      | 0,7                | 0,65               | 0,55               | 0,55    | 0,5     |

|             |                         |        |
|-------------|-------------------------|--------|
| <b>FD10</b> | : <b>RF-10</b> Ø75x108, | 1/2PF" |
| <b>FD30</b> | : <b>RF-30</b> Ø28x28,  | 1/8PF" |
| <b>FD35</b> | : <b>RF-35</b> Ø30x29,  | 1/8PF" |
| <b>FD40</b> | : <b>RF-40</b> Ø41x38,  | 3/8PF" |
| <b>FD45</b> | : <b>RF-45</b> Ø45x55,  | 3/8PF" |
| <b>FD50</b> | : <b>RF-50</b> Ø52x52,  | 3/8PF" |
| <b>FD75</b> | : <b>RF-75</b> Ø75x70,  | 1/2PF" |

**0:** SUS304  
**3:** SUS316

**1:**  
**2:**

|              |     |      |                            |
|--------------|-----|------|----------------------------|
| <b>D:</b> 50 | 200 | /240 | SPST                       |
| <b>F:</b> 10 | 125 |      | SPST                       |
| <b>G:</b> 60 | 220 |      | SPDT ( $\cong \phi 12.7$ ) |
| <b>H:</b> 3  | 30  | / 60 | SPST                       |

(  $\cong \phi 9.5$  )

**:** (N.O.) SPST  
**B:** (N.C.) SPST  
**C:** 1AB SPDT  
**D:** NC  
**E:** N

(XLPE125°C) ( . . =10 )  
**03:** 30 ( )  
**05:** 50  
**15:** 150

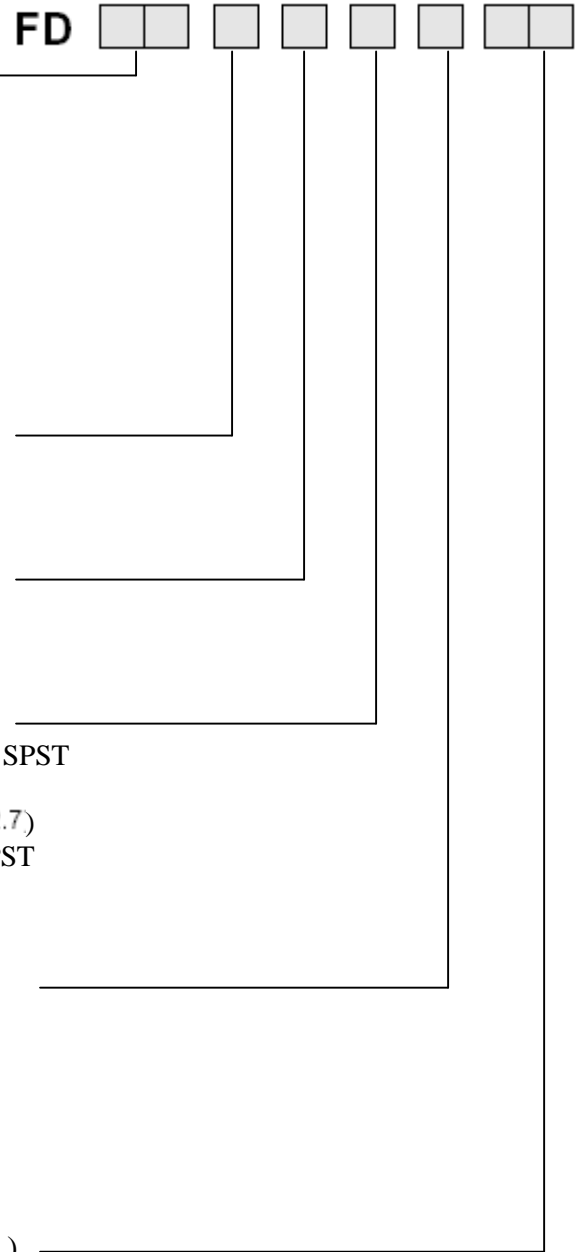

► FDSA□11

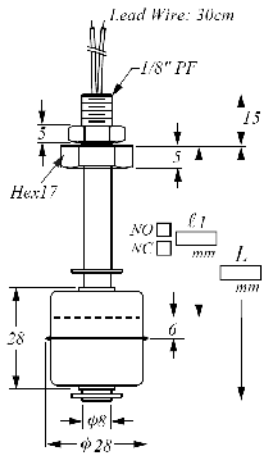

WASHER: NBR

► FDSB□11

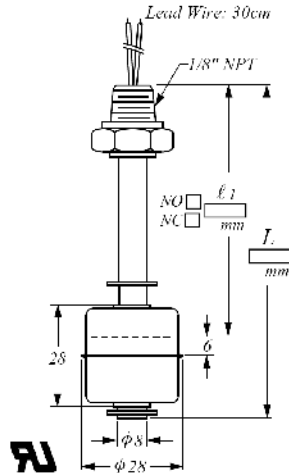

WASHER: NBR

► FDSC□11

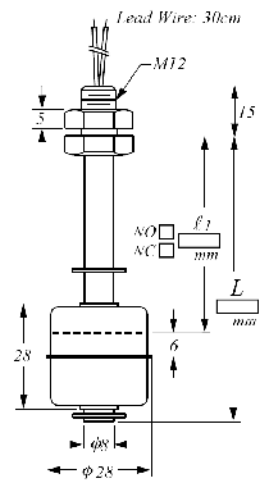

WASHER: NBR

► FDSA□12

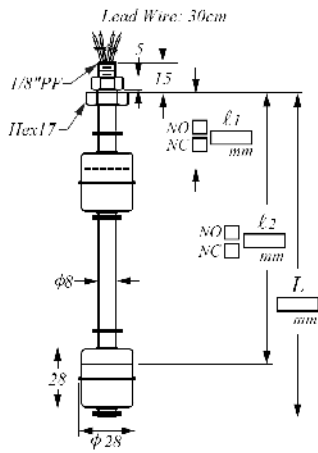

WASHER: NBR

► FDSA□21

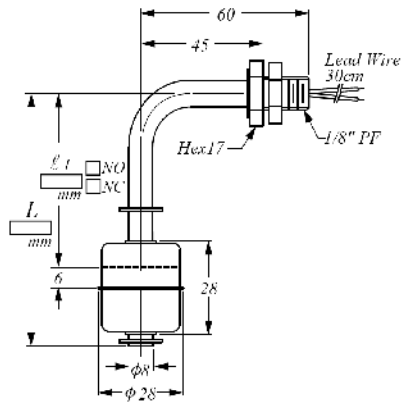

WASHER: NBR

► FDSA□22

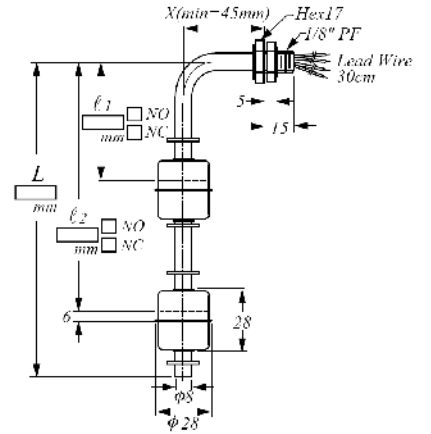

WASHER: NBR

► **FDSD□11**

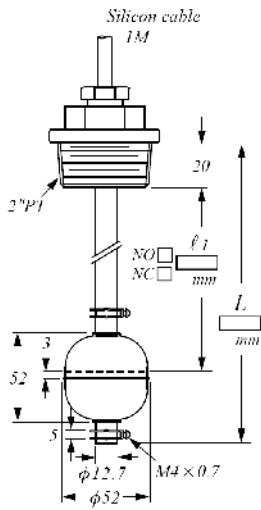

► **FDSE□11**

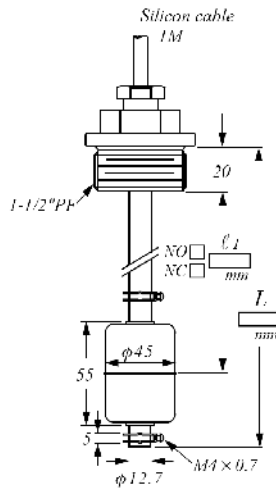

► **FDSF□11**

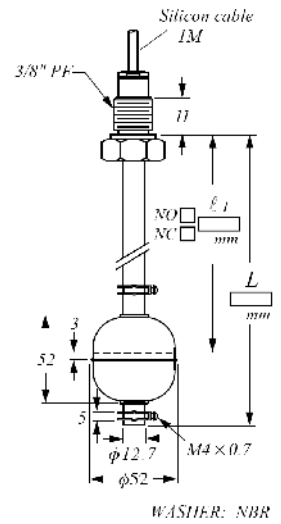

► **FD4503D**

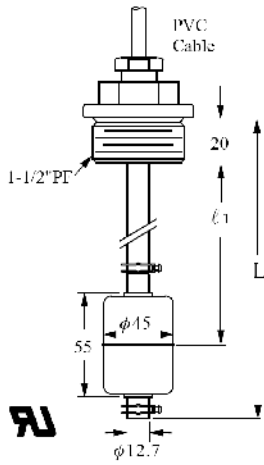

► **FD5003G**

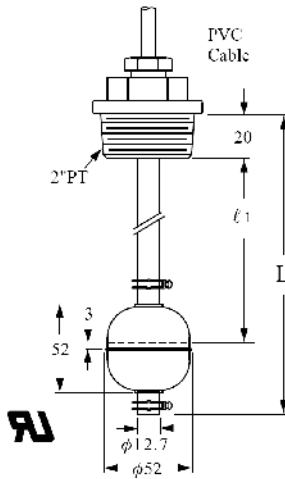

► **FD7503G**

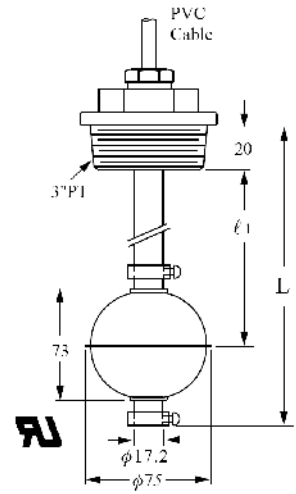

**FD** 

**FDSA** : **RF-SA** Ø28x28 1/8"PF  
**FDSB** : **RF-SB** Ø28x28 1/8"NPT  
**FDESC** : **RF-SC** Ø28x28 M12  
**FDSDF** : **RF-SD** Ø52x52 2"PT  
**FDSDE** : **RF-SE** Ø45x55 1-1/2"PF  
**FDSDF** : **RF-SF** Ø52x52 3/8"PF

**0:** SUS304  
**6:** SUS316  
**B:**

**1:**  
**2:**

1-2

**D:** 50 200 /240 SPST  
**F:** 10 125 SPST  
**G:** 60 220 SPDT (  $\cong \phi 12.7$  )

**:** (N.O.) SPST  
**B:** (N.C.) SPST  
**C:** 1AB SPDT

**03:** 30 ( SA, SB, SC ) ( . =10 )  
**05:** 50  
**10:** 100 ( SD, SE, SF )  
**15:** 150

▪ ± 5  
 ▪  
 ▪

